

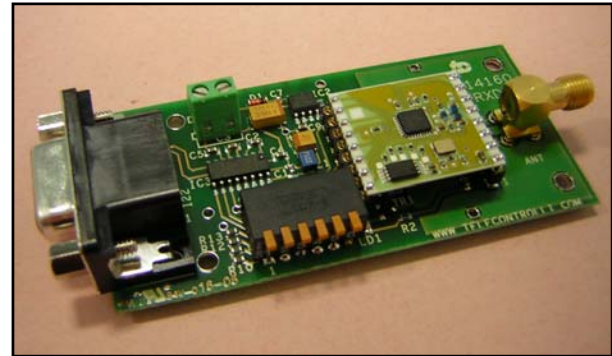

RXDL1 RS232 RADIO DATA LINK

- Evaluation board for **RXQ2-xxx** transceiver (Not included)
- RS232 driver and DB9F connector for direct interface to PC serial port
- Selectable 'Narrowband' RF Channels
- Signal LED of activity transmission
- Supply Voltage 5V to 12V
- Serial Data Interface with Handshake
- Host Data Rates up to 38,400 Baud
- Very Stable Operating Frequency
- Operates from -20 to +70 °C
- Size: 79.38 mm x 36.83 mm (excluding antenna)



RXDL1 with RXQ2 transceiver module on board
(SMA Connector not included)

Applications

- Remote Control
- Remote Meter Reading
- Sensor Data Logging
- EPOS Terminals

Description

The RXDL1 RS232 radio data link provides a reliable wireless communications for the transfer of data at Gaussian Frequency Shift Keying (GFSK), Manchester encoded, RF data rates of up to 100 kbps.

The interface board features an on board RXQ2 transceiver, with RS232 driver, 9 way D connector, 3,3V voltage regulator and SMA RF connector (not included). It requires just one supply voltage to power up and works without any additional interface circuit transmission.

Operating within the 433 (868) MHz band the module operates in user selectable channels. The RXQ2 embedded can use any channel in 100 (200) kHz steps. Preamble and CRC are automatically generated and added to the RF transmission.

Possible applications include one-to-one and multi-node wireless links in applications including car and building security, EPOS, inventory tracking, remote industrial process monitoring and computer networking.

Because of their small size and low power requirements, both modules are ideal for use in portable, battery-powered applications such as hand-held terminals.



Mechanical Details

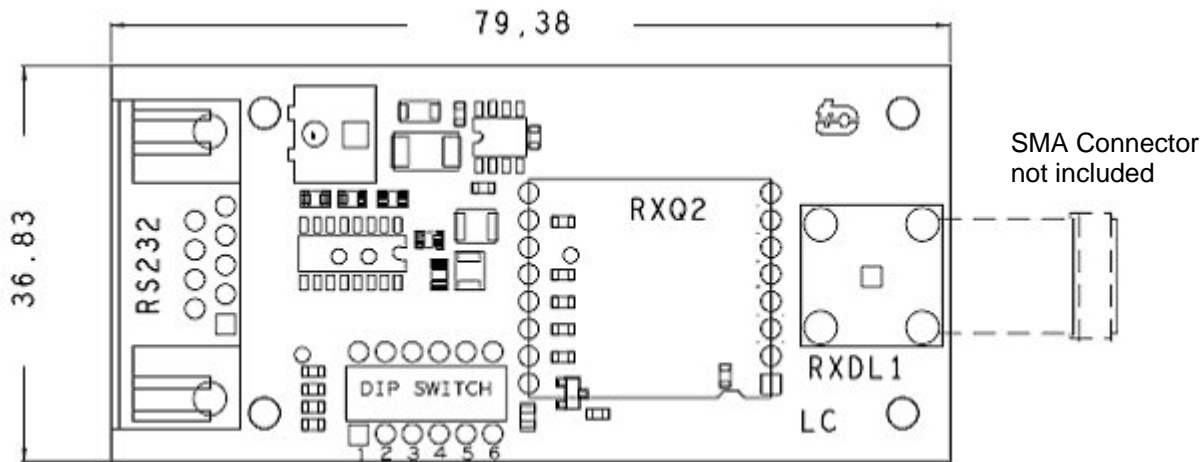

DIP Switch Configurations

DIP Switch	Name	Type	Description
1	PD (Power Down)	In	OFF : Power Down mode; ON : Operating mode.
2,3	Data Rate	In	Host Data Rate selection (see next table).
4	Configuration	In	OFF : Configuration mode; ON : Operating mode.
5	RTS	In	OFF, OFF : RTS,CTS <u>Disabled</u> (RS232 without handshake); ON, ON : RTS,CTS <u>Enabled</u> (RS232 with handshake).
6	CTS	Out	

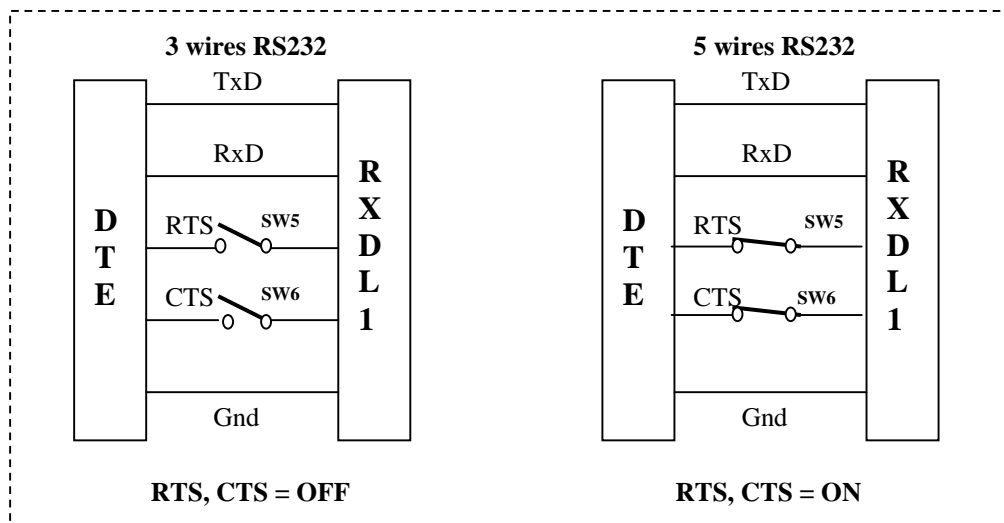

Host Data Rate Selection

DR1 (SW2)	DR2 (SW3)	Baud Rate
OFF	OFF	4,800
ON	OFF	9,600
OFF	ON	19,200
ON	ON	38,400



Technical Specifications

- Absolute Maximum Rating**

Operating temperature: -20 °C to +80 °C
 Storage temperature: -40 °C to +100 °C
 Supply Voltage: 5V to 12V

- Electrical Characteristics**

	Min.	Typ.	Max.	Units	Notes
DC Levels					
Supply voltage	5		12	V	
Supply current (Transmit mode @ +10 dBm)		31		mA	
Supply current (Receive mode)		23		mA	
RF					
Working frequency : 433 band 868 band	430.0 860.0		440.0 880.0	MHz	1
Receiver sensitivity		-100		dBm	
Transmitter RF power out		+10		dBm	
Frequency deviation		+/-50		kHz	
GFSK Manchester encoded data rate		100		kbps	
Operating temperature	-20		+70	°C	
Dynamic Timing					
Power up to stable receiver data out		30		msec	
Power up to full RF out		30		msec	
Standby to Receive mode		1		msec	
Standby to Transmit mode		1		msec	

Note

- The application operating frequency must be chosen to comply with the Short Range device regulation in the area of operation



Operation

The Host Data Rate switches (SW 2,3) are read when the PD switch goes high (SW1 = ON). The RXQ2 must be put into standby mode by taking the PD pin low (SW1 = OFF) in order to change the selection.

The size of RF data packets are set during configuration. If fewer bytes are received by the RXQ2 transceiver than the preset size, then after 10ms from the last byte received from the host, the RF packet will be processed (expanded to meet the preset packet size) and transmitted. The RF data packet size must be set the same for transmitter and receiver, otherwise the received packets will be discarded.

In order to optimize data rate, in a point-to-point configuration where data is mostly being sent in one direction, the packet size for one data direction can be set to the maximum size, however the reverse direction may be set to a smaller packet size, to implement an acknowledge reply for example.

No RF packets will be received by the module when it is in power down mode.

Each RXQ2 has its own preset address. This is set during configuration. Any data received is examined and the address header, embedded within the data packet, is compared with the RXQ2 address. Only data received with matching address will be processed and output to the host, all other data will be discarded.

All RXQ2 modules are shipped with a default address of 7E7E7E7E.

Block Diagram

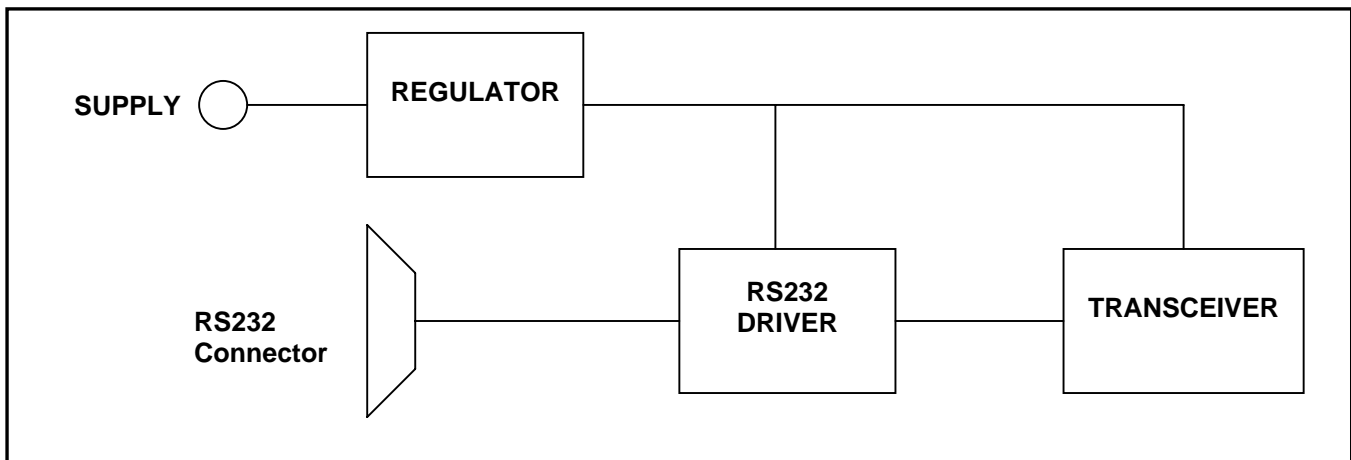



RXDL1 and embedded RXQ2 configuration

The configuration of the RXDL1 board may be changed by setting the Configuration switch low (SW4 = OFF) and sending a set of configuration data bytes.

Byte	Name	Description	Default Value (hex)
0	Destination Address	MSB	7E
1			7E
2			7E
3		LSB	7E
4	RXQ2 Address	MSB	7E
5			7E
6			7E
7		LSB	7E
8	RF Channel	100 kHz step (433 band) 200 kHz step (868 band)	6B (433,1 MHz) 75 (868,2 MHz)
9	Tx Power	00 = -10 dBm 01 = -2 dBm 02 = +6 dBm 03 = +10 dBm	00
10	Tx data packet size		1E (30 bytes)
11	Rx data packet size		1E (30 bytes)

The RF Channel is calculated as:

433 MHz working frequency : Configuration value (decimal) = (desired RF frequency - 422.4MHz) * 10

868 MHz working frequency : Configuration value (decimal) = [(desired RF frequency / 2) - 422.4MHz] * 10

Note : *calculated value must be converted into hexadecimal format.*

The RXDL1 is programmed through the same RS232 port that is used for sending/receiving data. An RS232 terminal emulator (such as LABVIEW™) is an ideal tool.

Connect the RXDL1 directly (or via serial straight through cable) to the PC serial port. To enter configure mode, put Configuration pin low (SW4 OFF) and run the LABVIEW™ program (RXQ2_Setting.vi: free download from our web site) : in this mode the radio link is disabled. The RS232 PC port should be set with the following settings:

8 bit data, no parity, 1 start bit, 1 stop bit, no flow control.

Data Rate is the same setted on the radio data link (see Host Data Rate Selection TAB).

After all parameters choice (Addresses, Frequency, Port, etc.) on the LABVIEW™ front panel, just run the program.

To return in the operating mode SW4 must be setted ON.

For further details on Configuration Mode, see also RXQ2 Transceiver Datasheet.



Antenna Design

The design and positioning of the aerial is as crucial as the module performance itself in achieving a good wireless system range. The following will assist the designer in maximizing system performance. The RF ground pin should be connected to a ground plane which should shield the aerial connection and the PCB layout around the aerial track itself should be such as to give a 50 Ohm impedance. The aerial should be kept as far away from sources of electrical interference as physically possible. The specified power supply decoupling capacitors should be placed close to the module as possible and have direct connections to the relevant pins.

The antenna 'hot end' should be kept clear of any objects, especially any metal as this can severely restrict the efficiency of the antenna to receive power. Earth planes restricting the radiation path of the antenna will also have the same effect.

The best range will be achieved with either a straight piece of wire, rod or PCB track @ $\frac{1}{4}$ wavelength. Increased range may be achieved if this $\frac{1}{4}$ wave antenna is placed perpendicular to and in the middle of a solid earth plane measuring at least 16cm radius. In this case, the antenna should be connected to the module using 50 Ohm coaxial cable and the PCB track layout tips given above should be observed.

Helical Antenna

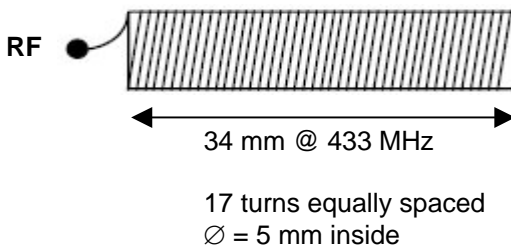

Whip Antenna

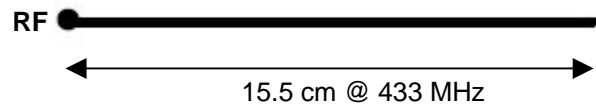

Helical Antenna

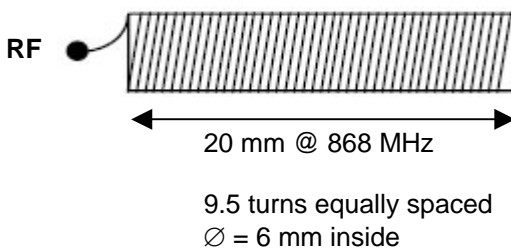

Whip Antenna

