

## Chapter 21 Temperature Measurement of FBs-PLC and PID Control

FBs-PLC provides two kinds of temperature modules to meet the great temperature measurement applications. One kind of these modules are directly interfacing with the thermocouple, and the others are interfacing with the RTD sensor. The modules FBs-TC2/FBs-TC6/FBs-TC16 support 2/6/16 temperature channels correspondingly to connect the J,K,T,E,N,B,R,S type of thermocouple. The modules FBs-RTD6/FBs-RTD16 support 6/16 temperature channels correspondingly to connect the PT-100,PT-1000 type of RTD sensor. The total temperature inputs can be expanded up to 32 channels at the most.

By the time domain multiplexing design method, each temperature module occupies 1 point of register input and 8 points of digital output for I/O addressing. The update rate for temperature reading value can be set as normal (Update time is 4 second, the resolution is 0.1°) or fast (Update time is 2 second, the resolution is 1°).

The Winproladder provides the very user friendly table editing operation interface to configure the temperature measurement, for example, selecting the temperature module, type of sensor, and assign the registers to store the reading values... As to the temperature control, it has the convenient instruction FUN86(TPCTL) to perform the PID operation to control the heating or cooling of the temperature process.

### 21.1 Specifications of temperature measuring modules of FBs-PLC

#### 21.1.1 Thermocouple input of FBs-PLC

Specifications Items	Module		
	FBs-TC2	FBs-TC6	FBs-TC16
Number of input points	2 Points	6 Points	16 Points
Thermocouple type and temperature measurement range	J(-200 ~ 900°C) K(-190 ~ 1300°C) R(0 ~ 1800°C) S(0 ~ 1700°C)	E(-190 ~ 1000°C) T(-190 ~ 380°C) B(350 ~ 1800°C) N(-200 ~ 1000°C)	
I/O Points Occupied	1 IR(Input Register) · 8 DO(Discrete Output)		
Software Filter	Moving Average		
Average Samples	NO · 2 · 4 · 8 Configurable		
Compensation	Built-in cold junction compensation		
Resolution	0.1°C		
Conversion Time	1 or 2 Sec.	2 or 4 Sec.	3 or 6 Sec.
Overall Precision	±(1%+1°C)		
Isolation	Transformer(Power) and photocouple(Signal) isolation (per-channel isolation)		
Internal Power Consumption	5V · 32mA		5V · 35mA
Power Input	24VDC-15%/+20% · 2VA max		
Indicator(s)	5V PWR LED		
Operating Temperature	0 ~ 60 °C		
Storage Temperature	-20 ~ 80°C		
Dimensions	40(W)x90(H)x80(D) mm		90(W) x90(H) x80(D) mm

### 21.1.2 RTD input of FBs-PLC

Specifications Items	Module	
	FBs-RTD6	FBs-RTD16
Number of input points	6 Points	16 Points
RTD type and temperature measurement range	3-wire RTD sensor JIS( $\alpha=0.00392$ ) or DIN( $\alpha=0.00385$ ) Pt-100(-200~850°C) Pt-1000(-200~600°C)	
I/O Points Occupied	1 IR(Input Register) · 8 DO(Discrete Output)	
Software Filter	Moving Average	
Average Samples	NO · 2 · 4 · 8 Configurable	
Resolution	0.1 °C	
Conversion Time	1 or 2 Sec.	2 or 4 Sec.
Overall Precision	±1 %	
Isolation	Transformer(Power) and photocouple(Signal) isolation (per-channel isolation)	
Internal Power Consumption	5V · 35mA	5V · 35mA
Power Input	24VDC-15%/+20% · 2VA max	
Indicator(s)	5V PWR LED	
Operating Temperature	0~60 °C	
Storage Temperature	-20~80°C	
Dimensions	40(W)x90(H)x80(D) mm	90(W) x90(H) x80(D)mm

## 21.2 The procedure of using FBs temperature module

### 21.2.1 Temperature measurement procedure

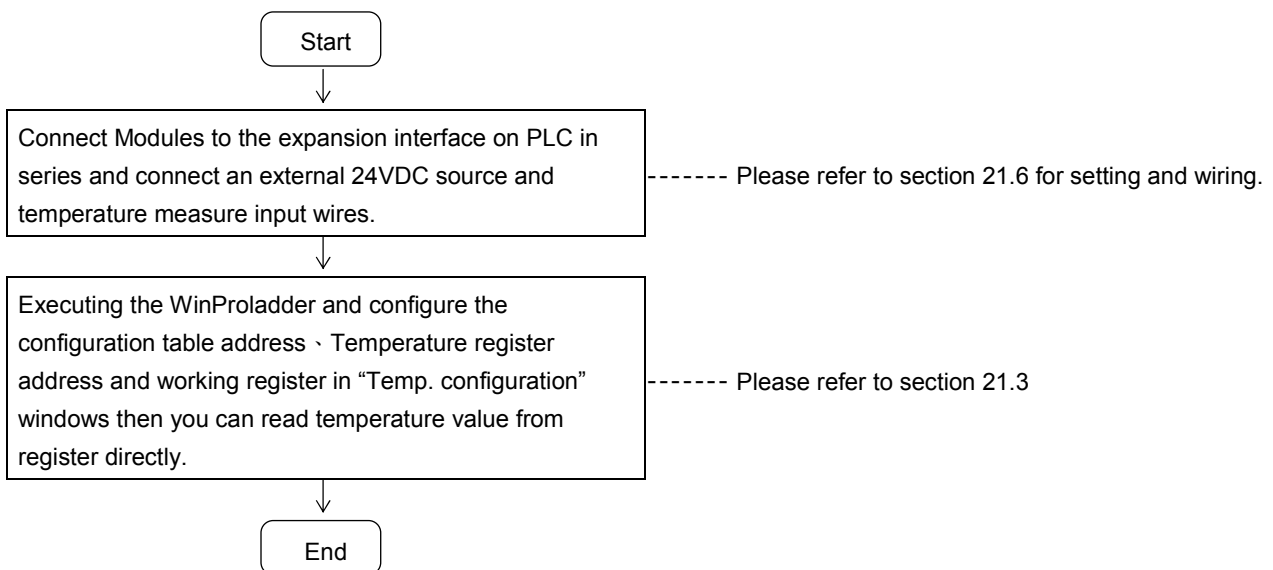

## 21.2.2 Closed loop PID temperature control

Start

Connect Modules to the expansion interface on PLC in series and connect an external 24VDC source and

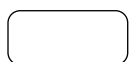

1. [ Starting Address of Configuration Table ] : Assign the starting of registers to store the temperature configuration table, there will allow the following inputs.

- a. Space (Without temperature configuration table)
- b. Rxxxx or Dxxxxx

The configuration table will occupy 4+N of registers, where N is the number of modules.

As shown the sample above, R5000~R5005 stores the table

2. [ .Starting Address of Temp. Register ] : Assign the starting of registers to store the current temperature reading values, there will allow the following inputs, Rxxxx or Dxxxxx ; 1 channel of temperature occupies 1 register as shown the sample above, R0~R31 stores the reading values. The resolution of reading value is 0.1°.

For example. R0=1234, it means 123.4°

3. [ Starting Address of Working Register ] : Assign the starting of registers to reserve the working registers, there will allow the following inputs Rxxxx or Dxxxxx

As shown the sample above, D0~D11 are the working registers

#### 【Temperature module installation information and setup】

4. [ Module #1 ~ # 8 ] : Display the name of the installed temperature module and the analog starting address of it's own, there are the following modules ◦

- ① TC6 (6 channels of thermocouple input)
- ② RTD6 (6 channels of RTD input)
- ③ TC16 (16 channels of thermocouple input)
- ④ RTD16 (16 channels of RTD input)
- ⑤ TC2 (2 channels of thermocouple input)

※The Sensor Type field is used to assign and display the sensor type, the detail Sensor Type please refer to section 21.1

5. [ Unit of Temperature ] : Assign the unit of temperature, there have the following selections

- ① Celsius
- ② Fahrenheit

6. [ Times of Average ] : Assign the times of average for temperature measurement, there have the following selections, No / 2 / 4 / 8.

7. [ Scan Rate ] : Assign the update rate of temperature reading value, there will have the following selections : Normal (Update time is 4 second, the measurement resolution is 0.1°), Fast (Update time is 2 second, the measurement resolution is 1°). The resolution of reading value is always 0.1°.

#### 21.3.1 The internal format of temperature configuration table

This introduction is for trouble shooting or HMI or SCADA User, because they may modify through registers. Winprolader's User can ignore this introduction. When you configure temperature configuration table with Winproladder, these value of registers will be finished. When SR+0 = A556h, it means valid temperature configuration table. But if SR+0 = other values, it means invalid temperature configuration table.

Address	High Byte	Low Byte
SR + 0	A5H	56H
SR + 1	Quantity of temperature modules (1~8)	
SR + 2	Starting address of reading values	
SR + 3	Starting address of working registers	
SR + 4	Type of sensor (#1)	Module name (#1)
SR + 5	Type of sensor (#2)	Module name (#2)
SR + 6	Type of sensor (#3)	Module name (#3)
SR + 7	Type of sensor (#4)	Module name (#4)
SR + 8	Type of sensor (#5)	Module name (#5)
SR + 9	Type of sensor (#6)	Module name (#6)
⋮	⋮	⋮

※ The temperature configuration table occupies (4 + N) registers in total ; where N is the quantity of modules.

### 21.3.2 The internal format of working registers

Supposing the starting address is WR

Address	High Byte	Low Byte
WR+0	Execute Code	XXXXH
WR+1	Sensor abnormal indicator (Sensor 0 ~ Sensor 15)	
WR+2	Sensor abnormal indicator (Sensor 16 ~ Sensor 31)	
WR+3	Total amount of TP channel	Qty of Temperature Module
WR+4	Type of sensor of Module #1	D.O. of TP Module #1
WR+5	Channel No. of Module #1	A.I. of TP Module #1
WR+6	Reading start of Temperature Module #1	
WR+7	Current channel of Temperature Module #1	
⋮	⋮	⋮
WR+(N×4)+0	Sensor of Module #N	D.O. of TP Module #N
WR+(N×4)+1	Channel No. of Module #N	A.I. of TP Module #N
WR+(N×4)+2	Reading start of Temperature Module #N	
WR+(N×4)+3	Current channel of Temperature Module #N	

Notes :

1. Lower byte of WR+0 : Tells the mismatch between the configuration table & installed temperature board

b0=1 , means module #1

⋮

⋮

⋮

b7=1 , means module #8

## 2. Upper byte of WR+0 : Execute Code

= 00H,Idle

= FFH,TP channel > 32, w/o temperature measurement

= FEH,lower byte of WR+3 = 0 or > 8, same as above

= 56H,already read all TP channels, measurement in progress

※ The working table occupies  $(N \times 4) + 4$  registers in total ; where N is the quantity of modules

### 21.3.3 Description of related special registers for temperature measurement

#### sensor's installation status

- R4010 : Each bit of R4010 to tell the status of the sensor's installation.  
Bit0=1 means that 1<sup>st</sup> point of temperature sensor is installed.  
Bit1=1 means that 2<sup>nd</sup> point of temperature sensor is installed.  
.  
.  
Bit15=1 means that 16<sup>th</sup> point of temperature sensor is installed.  
(The default of R4010 is FFFFH)
- R4011 : Each bit of R4011 to tell the status of the sensor's installation.  
Bit0=1 means that 17<sup>th</sup> point of temperature sensor is installed.  
Bit1=1 means that 18<sup>th</sup> point of temperature sensor is installed.  
.  
.  
Bit15=1 means that 32<sup>th</sup> point of temperature sensor is installed.  
(The default of R4011 is FFFFH)
- When the temperature sensor is installed (the corresponding bit of R4010 or R4011 must be 1), the system will perform the line broken detection to the sensor. If there is line broken happened to the sensor, there will have the warning and the line broken value will be displayed.
- When the temperature sensor is not installed (the corresponding bit of R4010 or R4011 must be 0), the system won't perform the line broken detection to the sensor and there will not have the warning; the temperature value will be displayed as 0.
- Depends on the sensor's installation, the ladder program may control the corresponding bit of R4010 and R4011 to perform or not to perform the line broken detection.

### 21.4 I/O addressing of temperature module

By the time domain multiplexing design method, each temperature module occupies 1 point of input register and 8 points of digital output for I/O addressing. For correct I/O access, the I/O addressing of expansion modules following the temperature module must be added the I/O quantity which the corresponding module should have. The WinProLadder provides the easy and convenient way to calculate the I/O address for the expansion modules through the on-line "I/O Numbering" operation.

### 21.5 Temperature modules hardware description

Temperature modules contains 3 PCBs overlapping one another. The lowest one is the power supply unit (isolated power supply). The middle one is the I/O board (connectors are on this layer). The upper one is the control board (control/expansion I/O connections) as described below.:

#### 21.5.1 FBs-TC2、TC6、TC16 outlook of top view

TC2

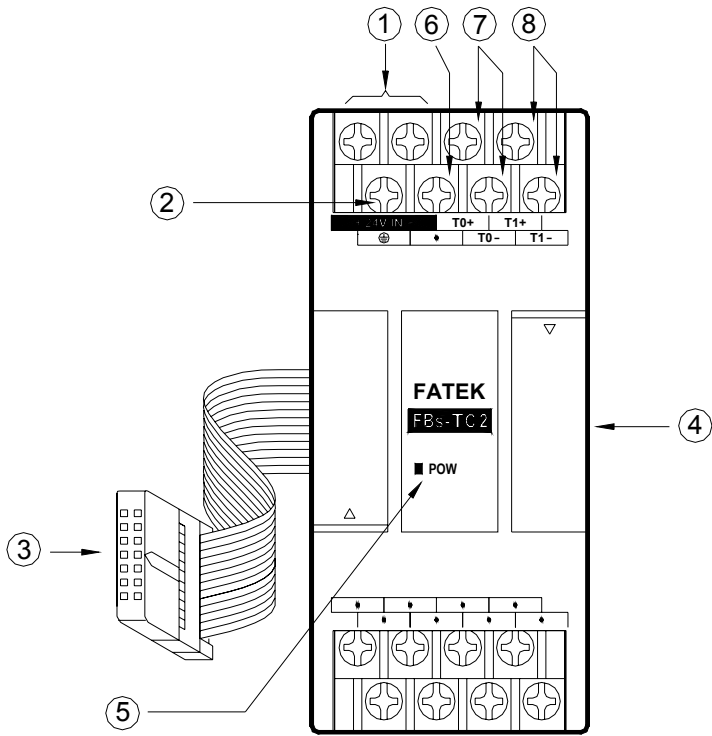

TC6

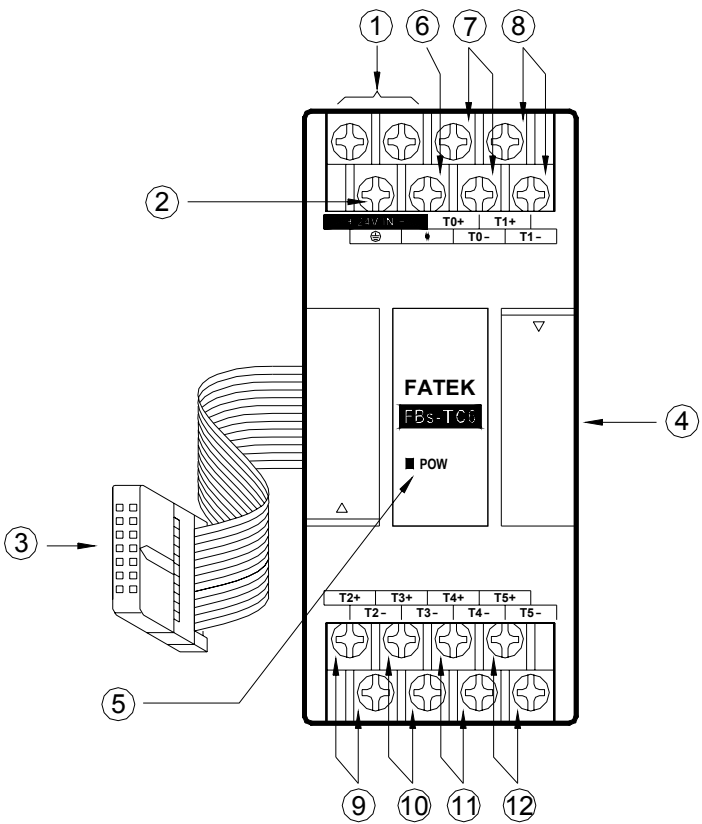

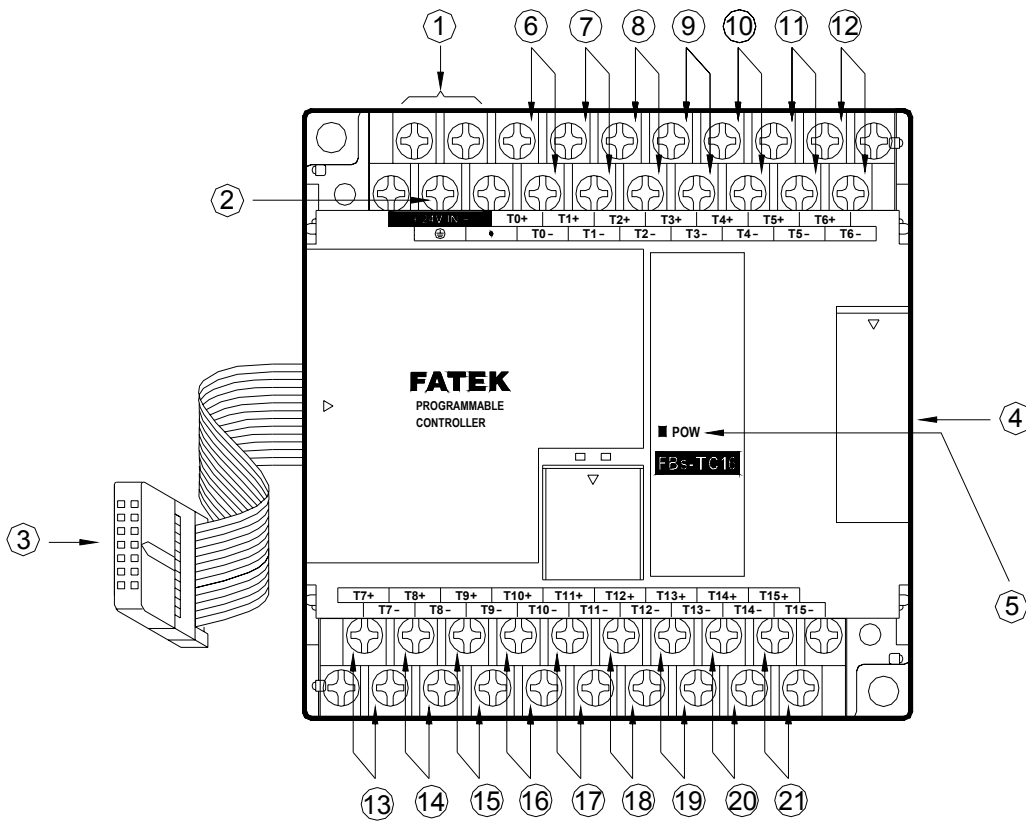

- ① External power input terminal : Power supply for analogue circuit of FBs-TCXX module, supply voltage is 24VDC±20%
- ② Protecting ground terminal : Connect to the shielding of signal cable.
- ③ Expansion input cable : It should be connected to the front expansion unit, or the expansion output of main unit.
- ④ Expansion output connector : Provides the connection for next expansion unit.
- ⑤ Power indicator: Indicates whether the power supply at analogue circuit and external input power source are normal.
- ⑥ Input terminal for 1<sup>st</sup> TC input : The TC input of channel0(T0+ 、 T0-)
- ⑦ Input terminal for 2<sup>nd</sup> TC input : The TC input of channel1(T1+ 、 T1-)
- ⑧~⑳ Input terminal for (3<sup>rd</sup> ~16<sup>th</sup>) TC input : The TC input of channel2~channel15(T2+ 、 T2-~T15+ 、 T15-)



21.5.2 FBs-RTD6、RTD16 outlook of top view

RTD6

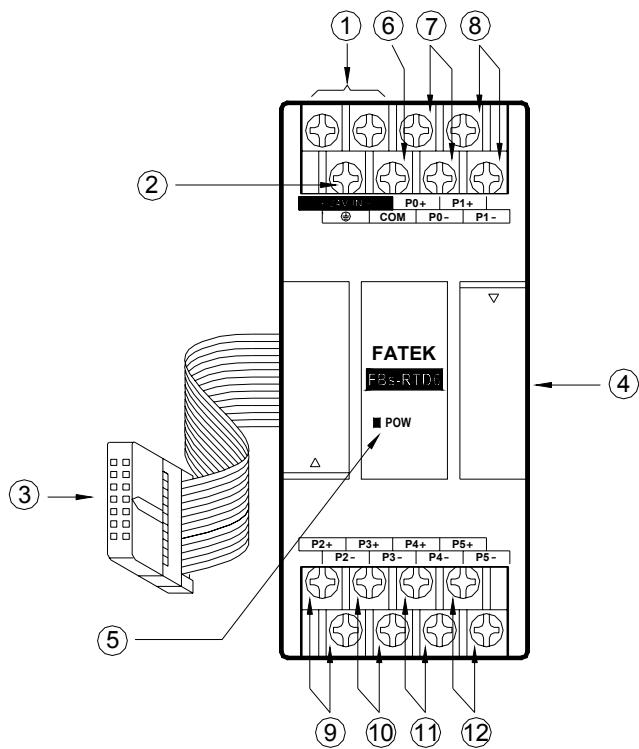

RTD16

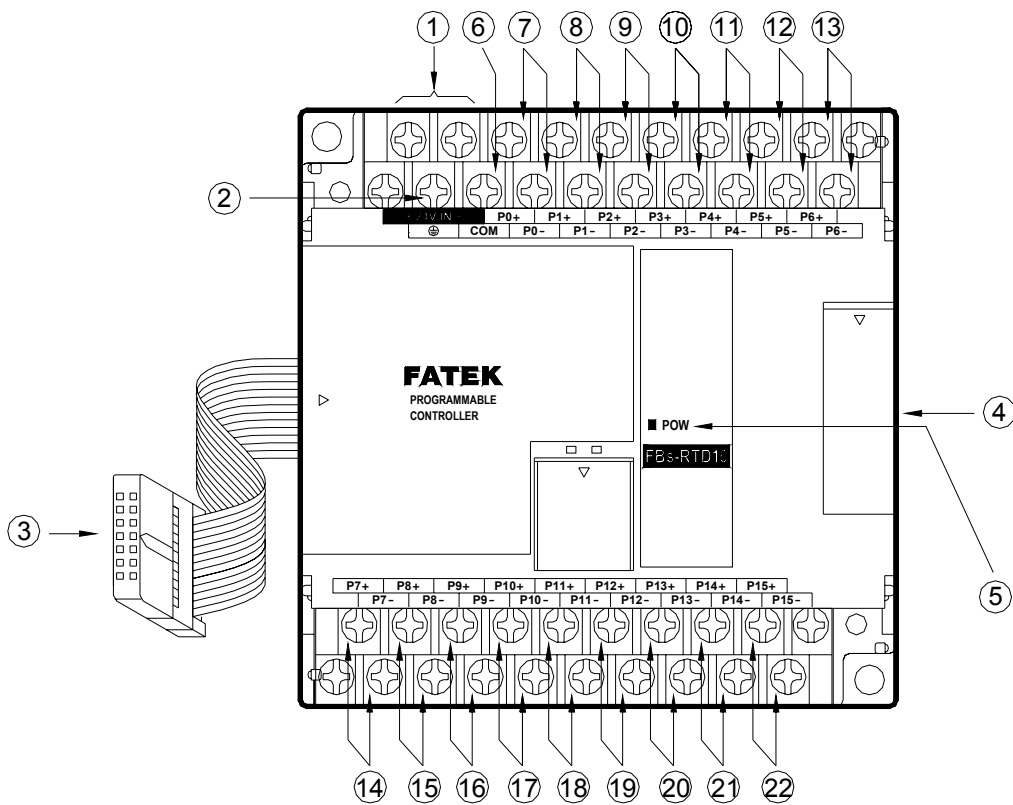

- ① External power input terminal : Power supply for analogue circuit of FBs-RTDXX module, supply voltage is 24VDC±20%
- ② Protecting ground terminal : Connect to the shielding signal cable.
- ③ Expansion input cable : It should be connected to the front expansion unit, or the expansion output of main unit.
- ④ Expansion output connector : Provides the connection for next expansion unit.
- ⑤ Power indicator: Indicates whether the power supply at analogue circuit and external input power source are normal.
- ⑥ Common terminal for 3-wires RTD input : To connect to the common wire of each 3-wires RTD input.
- ⑦ Input terminal for 1<sup>st</sup> RTD input : The RTD input of channel0(P0+、P0-)
- ⑧~⑳ Input terminal for (2<sup>nd</sup> ~ 16<sup>th</sup>) RTD input : The RTD input of channel1~15 (P1+、P1-~P15+、P15-)

## 21.6 Wiring of the temperature modules

### 21.6.1 Wiring of the thermocouple input module

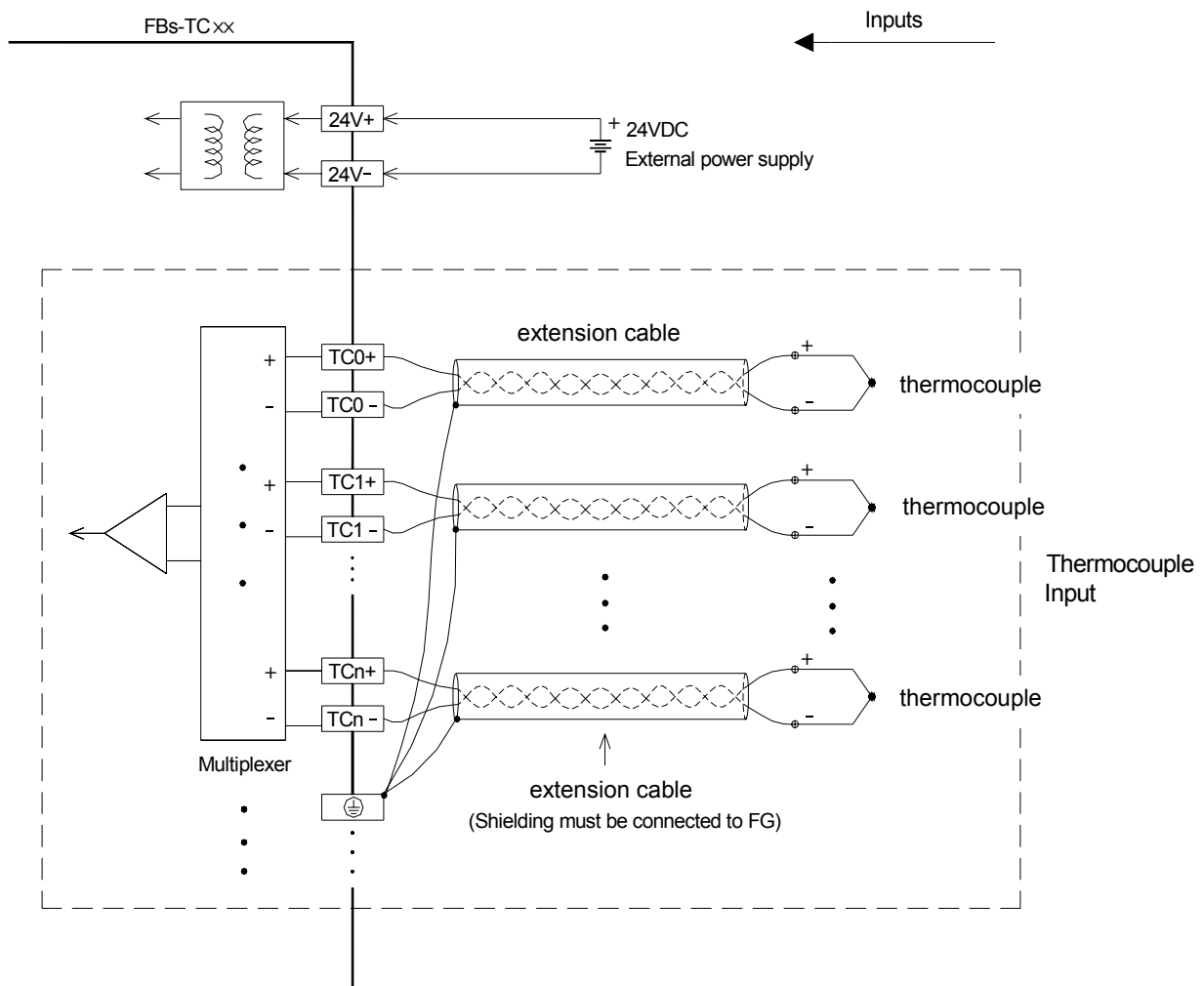

If it's FBs-TC6, n is 5  
 If it's FBs-TC16, n is 15

**21.6.2 Wiring of the RTD input module**

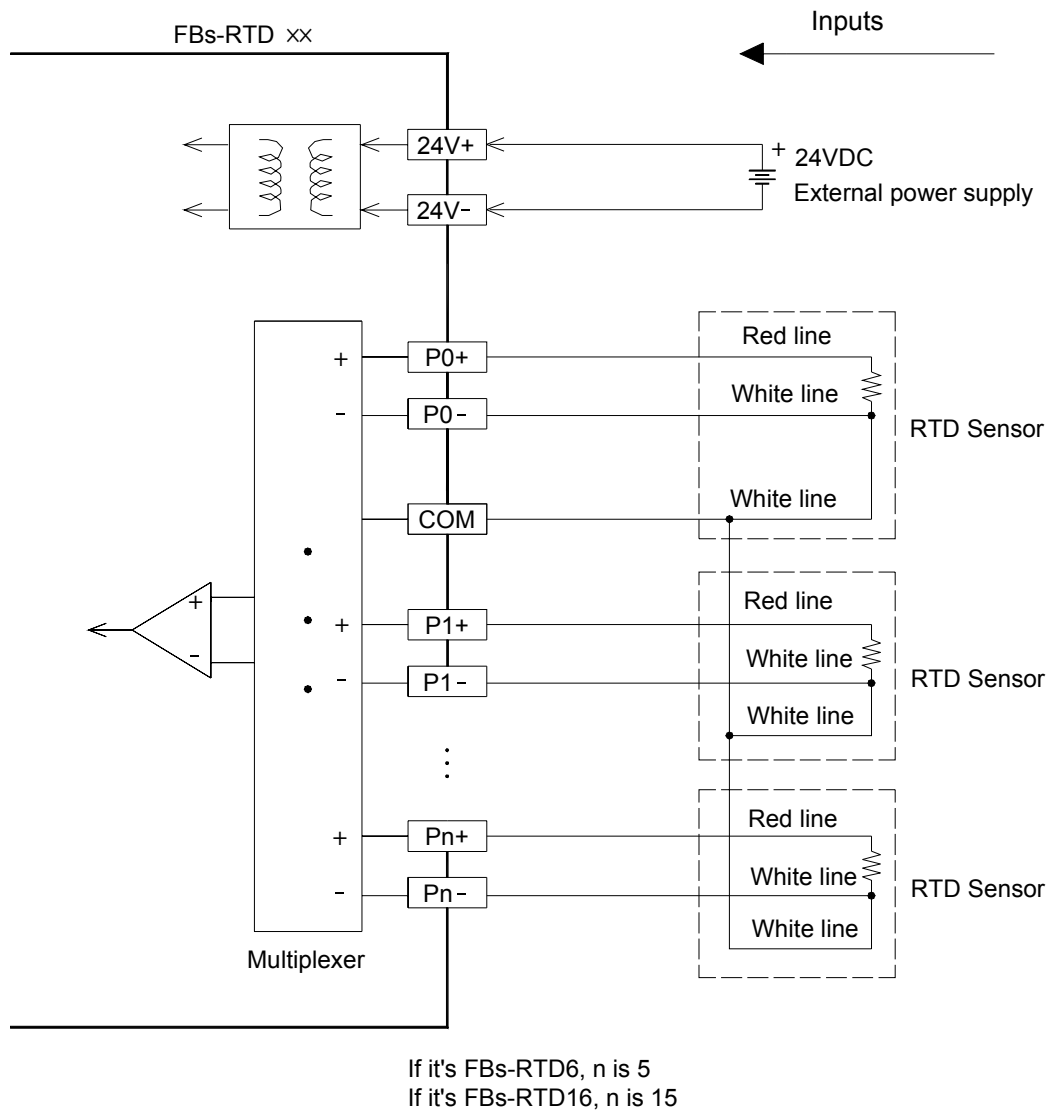

**21.7 Instructions explanation and program example for temperature measurement and PID temperature control of FBs-PLC**

The followings are the instructions explanation and program example for temperature measurement and PID temperature control of FBs-PLC.

Ladder symbol

86.TPCTL

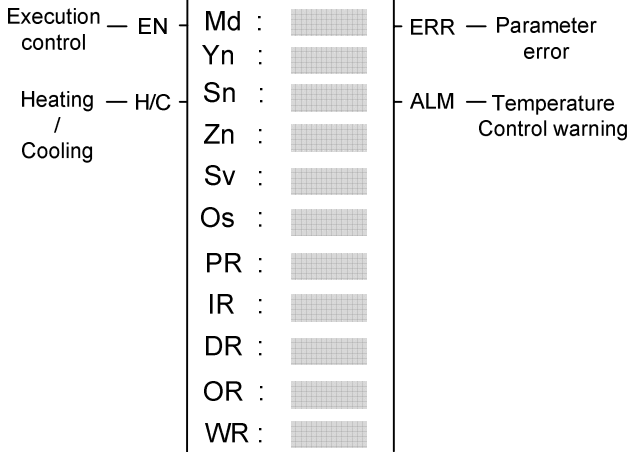

- Md : Selection of PID method  
=0, Modified minimum overshoot method  
=1, Universal PID method
- Yn : Starting address of PID ON/OFF output;  
it takes Zn points.
- Sn : Starting point of PID control of this instruction;  
Sn = 0~31.
- Zn : Number of the PID control of this instruction;  
1 ≤ Zn ≤ 32 and 1 ≤ Sn+Zn ≤ 32
- Sv : Starting register of the setpoint;  
it takes Zn registers. (Unit in 0.1°)
- Os : Starting register of the in-zone offset;  
it takes Zn registers. (Unit in 0.1°)
- PR : Starting register of the gain (Kc);  
it takes Zn registers.
- IR : Starting register of integral tuning constant (Ki);  
it takes Zn registers.
- DR : Starting register of derivative tuning constant  
(Td); it takes Zn registers.
- OR : Starting register of the PID analog output;  
it takes Zn registers.
- WR : Starting of working register for this instruction.  
It takes 9 registers and can't be repeated in  
using.

Range	Y	HR	ROR	DR	K
	Y0   Y255	R0   R3839	R5000   R8071	D0   D3999	
Operand					
Md					0~1
Yn	○				
Sn					0~31
Zn					1~32
Sv		○	○*	○	
Os		○	○*	○	
PR		○	○*	○	
IR		○	○*	○	
DR		○	○*	○	
OR		○	○*	○	
WR		○	○*	○	

- By employing the temperature module and table editing method to get the current value of temperature and let it be as so called Process Variable (PV); after the calculation of software PID expression, it will respond the error with an output signal according to the setting of Set Point (SP), the error's integral and the rate of change of the process variable. Through the closed loop operation, the steady state of the process may be expected.
- Convert the output of PID calculation to be the time proportional on/off (PWM) output, and via transistor output to control the SSR for heating or cooling process; this is a good performance and very low cost solution.
- Through the analog output module (D/A module), the output of PID calculation may control the SCR or proportional valve to get more precise process control.
- Digitized PID expression is as follows:

$$M_n = [K_c \times E_n] + \sum_0^n [K_c \times K_i \times T_s \times E_n] + [K_c \times T_d \times (P V_n - P V_{n-1}) / T_s]$$

M<sub>n</sub> : Output at time "n".

K<sub>c</sub> : Gain (Range: 1~9999 ; Pb=1000 / Kc ×0.1%, Unit in 0.1%)

K<sub>i</sub> : Integral tuning constant (Range:0~9999, equivalent to 0.00~99.99 Repeat/Minute)

T<sub>d</sub> : Derivative tuning constant (Range:0~9999, equivalent to 0.00~99.99 Minute)

PV<sub>n</sub> : Process variable at time "n"

PV<sub>n-1</sub> : Process variable when loop was last solved

E<sub>n</sub> : Error at time "n"; E= SP - PV<sub>n</sub>

T<sub>s</sub> : Solution interval for PID calculation (Valid value are 10, 20, 40, 80, 160, 320; the unit is in 0.1Sec)

**Principle of PID parameter adjustment**

- As the gain (Kc) adjustment getting larger, the larger the proportional contribution to the output. This can obtain a sensitive and rapid control reaction. However, when the gain is too large, it may cause oscillation. Do the best to adjust "Kc" larger (but not to the extent of making oscillation), which could increase the process reaction and reduce the steady state error.
- Integral item may be used to eliminate the steady state error. The larger the number (Ki, integral tuning constant,  $K_i=1/T_i$ ), the larger the integral contribution to the output. When there is steady state error, adjust the "Ki" larger to decrease the error.  
When the "Ki" = 0, the integral item makes no contribution to the output.

For example : if the reset time is 5 minutes,  $K_i=1/T_i=100/5=20$  ; It means integral tuning constant is 0.2 Repeat/Minute

- Derivative item may be used to make the process smoother and not too over shoot. The larger the number (Td, derivative tuning constant), the larger the derivative contribution to the output. When there is too over shoot, adjust the "Td" larger to decrease the amount of over shoot.  
When the "Td" = 0, the derivative item makes no contribution to the output.

For example : if the rate time is 1 minute, then the Td = 100; if the differential time is 2 minute, then the Td = 200.

- Properly adjust the PID parameters can obtain an excellent result for temperature control.
- The default solution interval for PID calculation is 4 seconds (Ts=40).
- The default of gain value (Kc) is 110, where  $P_b=1000/110 \times 0.1\% \doteq 0.91\%$ ; the system full range is 1638°, it means the value  $SP - 14.8^\circ$  ( $1638 \times 0.91 \doteq 14.8$ ) will let PID operation enter proportional band control.
- The default of integral tuning constant is 17
- The default of derivative tuning constant is 50, it means the rate time is 0.5 minutes (Td=50).
- When changing the PID solution interval, it may tune the parameters Kc, Ki, Td again.

**Instruction guide**

- FUN86 will be enabled after reading all temperature channels.
- When execution control "EN" = 1, it depends on the input status of H/C for PID operation to make heating (H/C=1) or cooling (H/C=0) control. The current values of measured temperature are through the multiplexing temperature module ; the set points of desired temperature are stored in the registers starting from Sv. With the calculation of software PID expression, it will respond the error with an output signal according to the setting of set point, the error's integral and the rate of change of the process variable. Convert the output of PID calculation to be the time proportional on/off (PWM) output, and via transistor output to control the SSR for heating or cooling process; where there is a good performance and very low cost solution. It may also apply the output of PID calculation (stored in registers starting from OR), by way of D/A analog output module, to control SCR or proportional valve, so as to get more precise process control.
- When the setting of Sn, Zn ( $0 \leq S_n \leq 31$  and  $1 \leq Z_n \leq 32$ , as well as  $1 \leq S_n + Z_n \leq 32$ ) comes error, this instruction will not be executed and the instruction output "ERR" will be ON.
- This instruction compares the current value with the set point to check whether the current temperature falls within deviation range (stored in register starting from Os). If it falls in the deviation range, it will set the in-zone bit of that point to be ON; if not, clear the in-zone bit of that point to be OFF, and make instruction output "ALM" to be ON.

FUN86 TPCTL	Convenient Instruction of PID Temperature Control	FUN86 TPCTL
----------------	---	----------------

- In the mean time, this instruction will also check whether highest temperature warning (the register for the set point of highest temperature warning is R4008). When successively scanning for ten times the current values of measured temperature are all higher than or equal to the highest warning set point, the warning bit will set to be ON and instruction output “ALM” will be ON. This can avoid the safety problem aroused from temperature out of control, in case the SSR or heating circuit becomes short.
- This instruction can also detect the unable to heat problem resulting from the SSR or heating circuit runs open, or the obsolete heating band. When output of temperature control turns to be large power (set in R4006 register) successively in a certain time (set in R4007 register), and can not make current temperature fall in desired range, the warning bit will set to be ON and instruction output “ALM” will be ON.
- WR: Starting of working register for this instruction. It takes 9 registers and can't be repeated in using. The content of the two registers WR+0 and WR+1 indicating that whether the current temperature falls within the deviation range (stored in registers starting from Os). If it falls in the deviation range, the in-zone bit of that point will be set ON; if not, the in-zone bit of that point will be cleared OFF.  
 Bit definition of WR+0 explained as follows:  
 Bit0=1, it represents that the temperature of the Sn+0 point is in-zone...  
 Bit15=1, it represents that the temperature of the Sn+15 point is in-zone.  
 Bit definition of WR+1 explained as follows:  
 Bit0=1, it represents that the temperature of the Sn+16 point is in-zone...  
 Bit15=1, it represents that the temperature of Sn+31 point is in-zone.  
 The content of the two registers WR+2 and WR+3 are the warning bit registers, they indicate that whether there exists the highest temperature warning or heating circuit opened.  
 Bit definition of WR+2 explained as follows:  
 Bit0=1, it means that there exists the highest warning or heating circuit opened at the Sn+0 point...  
 Bit15=1, it means that there exists the highest warning or heating circuit opened at the Sn+15 point.  
 Bit definition of WR+11 explained as follows:  
 Bit0=1, it means that there exists the highest warning or heating circuit opened at the Sn+16 point...  
 Bit15=1, it means that there exists the highest warning or heating circuit opened at the Sn+31 point.  
 Registers of WR+4 ~ WR+8 are used by this instruction.
- It needs separate instructions to perform the heating or cooling control.

**Specific registers related to FUN86**

- R4005 : The content of Low Byte to define the solution interval between PID calculation
  - =0, perform the PID calculation every 1 seconds.
  - =1, perform the PID calculation every 2 seconds.
  - =2, perform the PID calculation every 4 seconds. (System default)
  - =3, perform the PID calculation every 8 seconds.
  - =4, perform the PID calculation every 16 seconds.
  - ≥5, perform the PID calculation every 32 seconds
- : The content of High Byte to define the cycle time of PID ON/OFF (PWM) output.
  - =0 · PWM cycle time is 1 seconds.
  - =1 · PWM cycle time is 2 seconds. (System default)
  - =2 · PWM cycle time is 4 seconds.
  - =3 · PWM cycle time is 8 seconds.
  - =4 · PWM cycle time is 16 seconds.
  - ≥5 · PWM cycle time is 32 seconds.

Note 1 : When changing the value of R4005, the execution control "EN" of FUN86 must be set at 0. The next time when execution control "EN" =1, it will base on the latest set point to perform the PID calculation.

Note 2 : The smaller the cycle time of PWM, the more even can it perform the heating. However, the error caused by the PLC scan time will also become greater. For the best control, it can base on the scan time of PLC to adjust the solution interval of PID calculation and the PWM cycle time.

- R4006 : The setting point of large power output detection for SSR or heating circuit opened, or heating band obsolete. The unit is in % and the setting range falls in 80~100(%); system default is 90(%).
- R4007 : The setting time to detect the continuing duration of large power output while SSR or heating circuit opened, or heating band obsolete. The unit is in second and the setting range falls in 60~65535 (seconds); system default is 600 (seconds).
- R4008 : The setting point of highest temperature warning for SSR, or heating circuit short detection. The unit is in 0.1 degree and the setting range falls in 100~65535; system default is 3500 (Unit in 0.1°).
- R4012 : Each bit of R4012 to tell the need of PID temperature control.  
 Bit0=1 means that 1<sup>st</sup> point needs PID temperature control.  
 Bit1=1 means that 2<sup>nd</sup> point needs PID temperature control.  
 .  
 .  
 Bit15=1 means that 16<sup>th</sup> point needs PID temperature control.  
 (The default of R4012 is FFFFH)
- R4013 : Each bit of R4013 to tell the need of PID temperature control.  
 Bit0=1 means that 17<sup>th</sup> point needs PID temperature control.  
 Bit1=1 means that 18<sup>th</sup> point needs PID temperature control.  
 .  
 .  
 Bit15=1 means that 32<sup>th</sup> point needs PID temperature control.  
 (The default of R4013 is FFFFH)
- While execution control "EN"=1 and the corresponding bit of PID control of that point is ON (corresponding bit of R4012 or R4013 must be 1), the FUN86 instruction will perform the PID operation and respond to the calculation with the output signal.
- While execution control "EN"=1 and the corresponding bit of PID control of that point is OFF (corresponding bit of R4012 or R4013 must be 0), the FUN86 will not perform the PID operation and the output of that point will be OFF.
- The ladder program may control the corresponding bit of R4012 and R4013 to tell the FUN86 to perform or not to perform the PID control, and it needs only one FUN86 instruction.

Program example

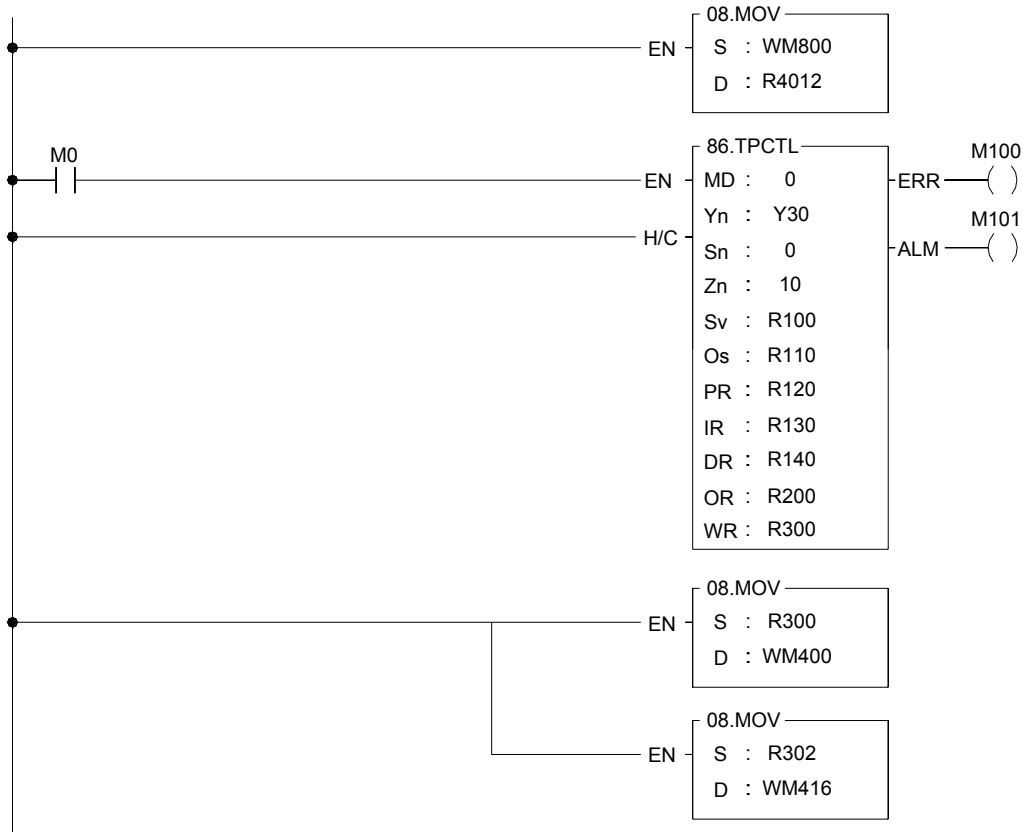

Description

- The status of M800~M815 are controlled by the MMI or external inputs to tell which temperature channel needs PID control; if the corresponding bit is ON, it means yes; if the bit is OFF, it means no PID control.
- When M0=ON, it will perform the PID heating control of 10 (Zn=10) channels from channel 0 (Sn=0) to channel 9.
- Y30 ~ Y39 : PID ON/OFF (PWM) output; they must be the transistor outputs.
- R100~R109 : Registers of set point (Unit in 0.1°).
- R110~R119 : Registers of deviation zone (Unit in 0.1°), it determines whether the temperature falls into setting range.  
E.g. Set point is 2000 (200.0°) and deviation zone is 50 (5.0°), then  
1950 (195.0°) ≤ Current value ≤ 2050 (205.0°) means the temperature is in zone.
- R120~R129 : Setting point of gain .
- R130~R139 : Setting point of integral tuning constant .
- R140~R149 : Setting point of derivative tuning constant .
- R200~R209 : Output of PID calculation (Value from 0~16383).
- R300~R308 : Working registers, they can't be repeated in use.
- When the setting of Sn, Zn comes error, this instruction will not be executed and output M100 will be ON.



FUN86 TPCTL	Convenient Instruction of PID Temperature Control	FUN86 TPCTL
<ul style="list-style-type: none"><li>● When one of the temperatures is not in zone, or there exists highest temperature warning or heating abnormal, the output M101 will be ON.</li><li>● M400~M409 : The temperature in zone indicators.</li><li>● M416~M425 : To tell the highest temperature warning or heating abnormal channel.</li></ul> <p>Note : When performing the instruction of the first time, the system will automatically assign the default value of gain (Kc), integral tuning constant (Ki), and derivative tuning constant (Td) for each channel. They can be changed while application tuning.</p>		



# MEMO

