

## RXQ7-868-ORP Sub 1 GHz 20dBm Radio Transceiver

### Features

- Max output power +20dBm
- Multiple type of signal modulation (OOK/FSK/GFSK)
- Selectable RF channels
- Data Rates up to 256 kbps (FSK) and 40 kbps (OOK).
- Supply Voltage: 1.8V to 3.6V
- Very Stable Operating Frequency
- DIL Package
- Operates from -20 to +55°C
- Ultra low power
- High Speed 8051  $\mu$ C CORE
- Up to 11 digital IO
- Up to 10 analog input

### Applications

- AMR – Automatic Meter Reading
- Wireless Alarm & Security Systems
- Home & Building Automation
- Wireless Sensor Networking
- Industrial Monitoring & Controls
- Multi channel bidirectional radio control
- Multi channel radio modem
- Multi channel radio transmitter
- Multi channel radio receiver

### Module versions

- RXQ7-434-ORP, RXQ7SMD-434-ORP
- RXQ7-868-ORP, RXQ7SMD-868-ORP
- RXQ7-915-ORP, RXQ7SMD-915ORP

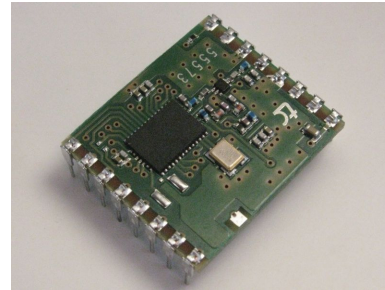

### General Description

The RXQ7-868-ORP (Open Radio Platform) is a radio module that allows the user an easy development and loading of his own application, thanks to the software/firmware platform inside the product.

The hardware module is based on Silicon Labs Si1010 wireless MCU. Main characteristics of the transceiver are: frequency working range 240-960 MHz, power output up to +20 dBm, integrated High Speed 8051  $\mu$ C CORE. The devices provides an on-chip debug circuitry for in-system debug (no emulator required) and 16 Kbytes ISP FLASH. Further dedicated 512 bytes of “scratchpad” memory can be used to store non-volatile data.

This module provides reliable wireless communications for data transfer rate up to 256 kbps. Its unique features of narrow band operation and user channel selection combined with excellent interference rejection make it an ideal choice for next generation applications.

The module uses a crystal controlled design that provides narrow band performance far better than other wideband ‘SAW’ based designs.

The circuit is mainly intended for the ISM (Industrial, Scientific and Medical), more precisely SRD (Short Range Device) applications; these modules allow simple connection, thanks to the UART interface. Possible applications include mono or bidirectional one-to-one and multi-node wireless links in

sectors like automatic metering reading, car and building security, inventory tracking, remote industrial process monitoring and computer networking.

Due to their small size and low power requirements, these modules are ideal choice for use in portable, battery-powered applications such as hand-held terminals.

The software platform provides an embedded bootloader that allow to load applications without hardware programmer. A test firmware (on board) gives the possibility to check the basic module functionalities. More applications will be available (soon on our web site) to evaluate it or to develop custom applications. We released a program named “RXQ7 Configuration utility” (see ‘User guide to RXQ7 firmware test’) to manage the bootloader and the test firmware .

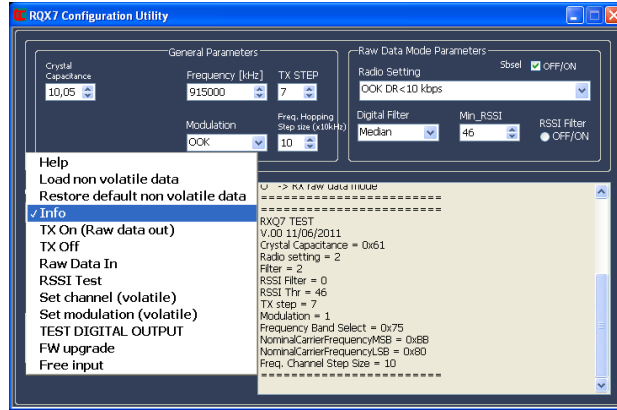

### Typical application circuit

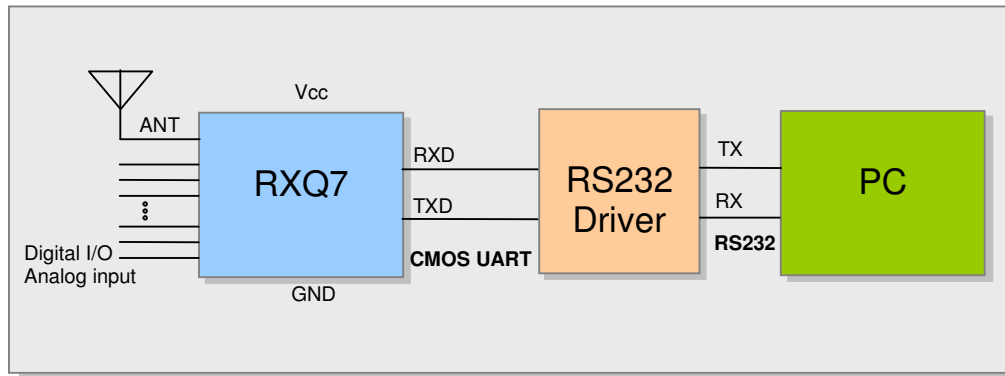
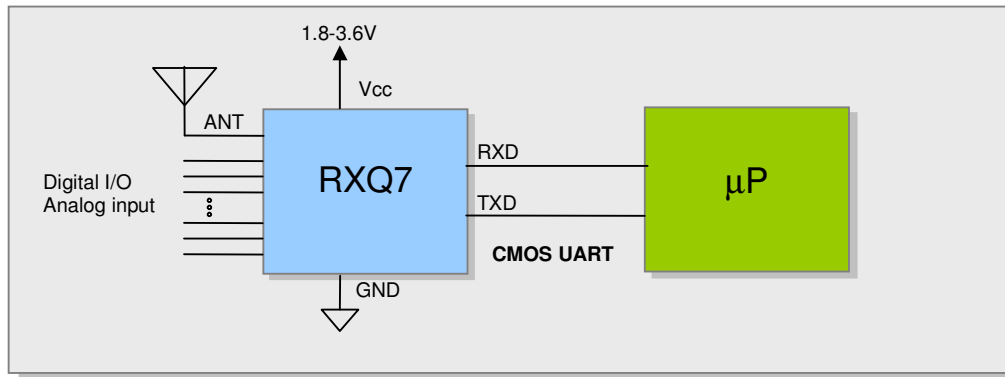

### Part number, description and package

Part Number	Description	Package
RXQ7-868-ORP	Multichannel Transceiver Module	16 pin DIL

## Pin description

<b>RXQ7 Pin</b>	<b>Name</b>	<b>Si1010 Pin</b>	<b>Type</b>
1	Vcc	16, 38	Supply voltage
2	P1.5	5	D I/O or A In
3	GPIO_0	24	D I/O or A In
4	GND	23, 37	Ground
5	ANT	-	Antenna
6	GND	23, 37	Ground
7	P2.7	40	D I/O
8	-RST	39	RESET (internal pullup)
9	P0.6	30	D I/O or A In
10	TXD	31	UART RX D I/O or A In
11	RXD	32	UART TX D I/O or A In
12	P0.0	36	D I/O or A In
13	P1.4	6	D I/O or A In
14	P0.2	34	D I/O or A In
15	P0.3	33	D I/O or A In
16	P0.7	29	D I/O or A In

## Mechanical Details

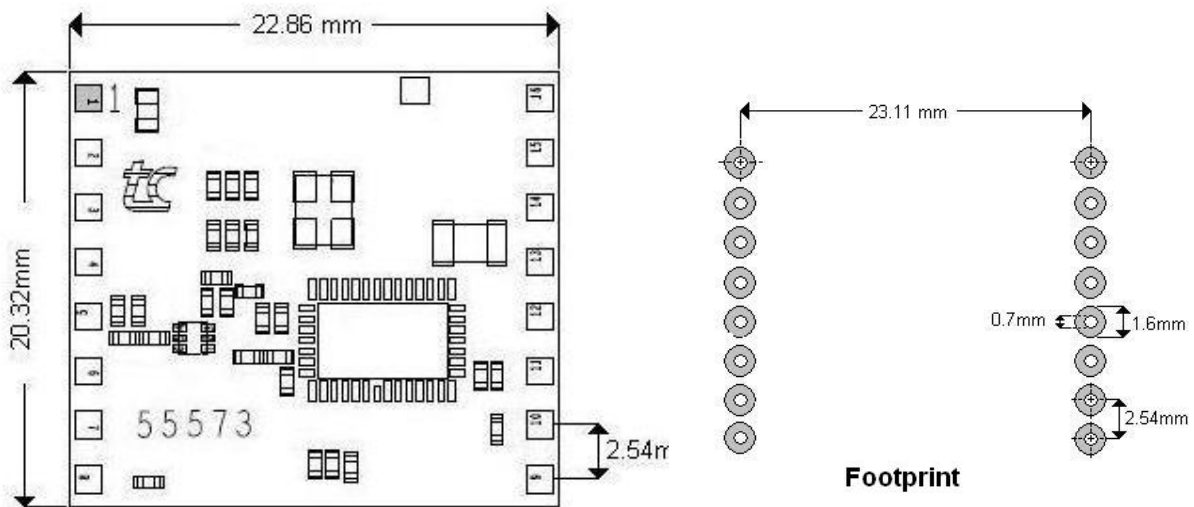

DIL16 package drawing

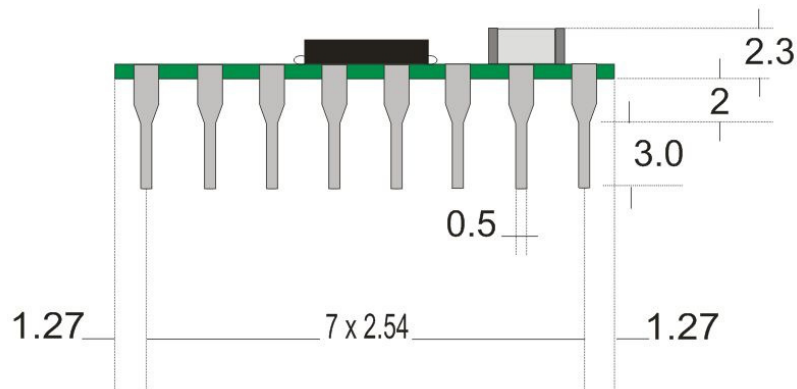

## Electrical Characteristics

Parameter	MIN	TYP	MAX	UNIT	Notes
V <sub>cc</sub> Supply Voltage	1.8	3.0	3.6	V	
I <sub>cc</sub> MCU active Supply current	-	4.0		mA	V <sub>cc</sub> 1.8-3.6V, F=24.5Mhz Radio in shutdown mode
I <sub>cc</sub> MCU Supply current idle mode	-	2.1	3.0	mA	V <sub>cc</sub> 1.8-3.6V, F=24.5Mhz Radio in shutdown mode
I <sub>cc</sub> MCU Supply current sleep mode	-	2	-	μA	V <sub>cc</sub> 1.8-3.6V, F=24.5Mhz Radio in shutdown mode
I <sub>dd</sub> Radio Supply current shutdown	-	15	50	nA	V <sub>dd</sub> 1.8-3.6V
I <sub>dd</sub> Radio Supply current standby		450	800	nA	V <sub>dd</sub> 1.8-3.6V
I <sub>dd</sub> Radio Supply current sleep		1		μA	V <sub>dd</sub> 1.8-3.6V
I <sub>dd</sub> Radio Supply current RX	-	18.5	-	mA	
I <sub>dd</sub> Radio Supply current TX	-	85	-	mA	Max output power. See figure 1
I <sub>dd</sub> Radio Supply current TX	-	17	-	mA	Min output power. See figure 1
Synthesizer Freq. Resolution		312.5		Hz	
Initial frequency accuracy		+/-15		ppm	25 °C
RX Frequency Range CEPT/ERC/REC 70-03	868.0	-	870.0	MHz	
Receiver sensitivity		-108		dBm	(BER < 0.1%) (40 kbps, GFSK, BT = 0.5, Δf = +/-20 kHz)
RX Channel Bandwidth	2.6		620	kHz	
Harmonics			-30	dBm	
Output Power Range (50Ω)	-3	-	+20	dBm	8 steps controlled by txpow[2:0]. See figure 2.
TX data rate FSK	0.123	-	256	kbps	
Operating Temperature Range	-20		55	°C	
TX data rate OOK	0.123	-	40	kbps	
Flash Size		16384		bytes	512 bytes at addresses 0x3800 to 0x3BFE are used for bootloader. 1024 bytes at addresses 0x3C00 to 0x3FFF are reserved .
Working temperature	-20		55	°C	

See Silicon Lab's Si1010 datasheet for more details.

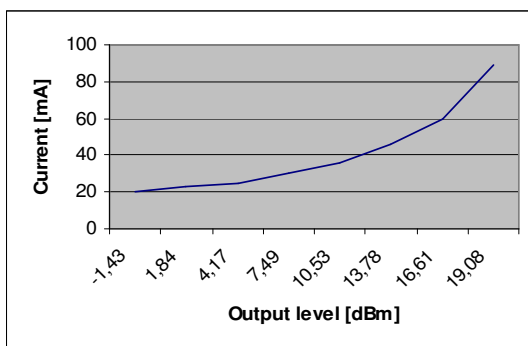

Figure 1: Typical module supply current in TX mode (with firmware test)

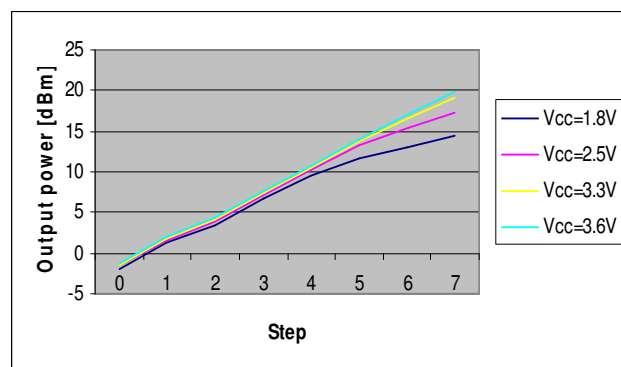

Figure 2: Typical Transmitter RF power out

MCU State	Radio state	Icc	Unit	Note
Sleep	Stand-by	1,2	μA	
Normal	TX	89,16	mA	Max output level
Idle	Stand-By	4,04	mA	
Sleep	Sleep	13,2	μA	P0.3 digital in to GND
Normal	RX	23,5	mA	

Table 1: Typical module supply current with firmware TX\_LP.HEX and RX\_LP.HEX)  
(Application note *'Packet transmission and receiving in power saving mode'*)

#### Related documents:

- *'User guide to RXQ7 firmware test'*
- *'Packet transmission and receiving in power saving mode'*

Telecontrolli Srl has an on going policy to improve the performance and reliability of their products; we therefore reserve the right to make changes without notice. The information contained in our data sheets is believed to be accurate, however we do not assume any liability arising from the application or use of any product or circuit.



Web Site: [www.telecontrolli.com](http://www.telecontrolli.com)

#### HEAD OFFICE & PLANT

Via Nazionale delle Puglie, 177  
80026 CASORIA (NA), Italy  
Tel: +39 081 7599033  
Fax: +39 081 7596494

#### SALES OFFICE

[sales@telecontrolli.com](mailto:sales@telecontrolli.com)