

# Chapter 2 System Architecture

## 2.1 Single-Unit System of FBS-PLC

The Single-Unit system means a system built only by a single FBS-PLC and its expansion unit/modules and communication boards/modules. Such system have a limited capability (refer), beyond that capability can incorporate CPU communication via LINK function for expansions (please refer to the next paragraph). The figure below shows the block diagram of the Single-Unit system of FBS-PLC, where, besides the available main units , the available communication peripherals resources and I/O expansion resources are depict on the left and the right respectively.

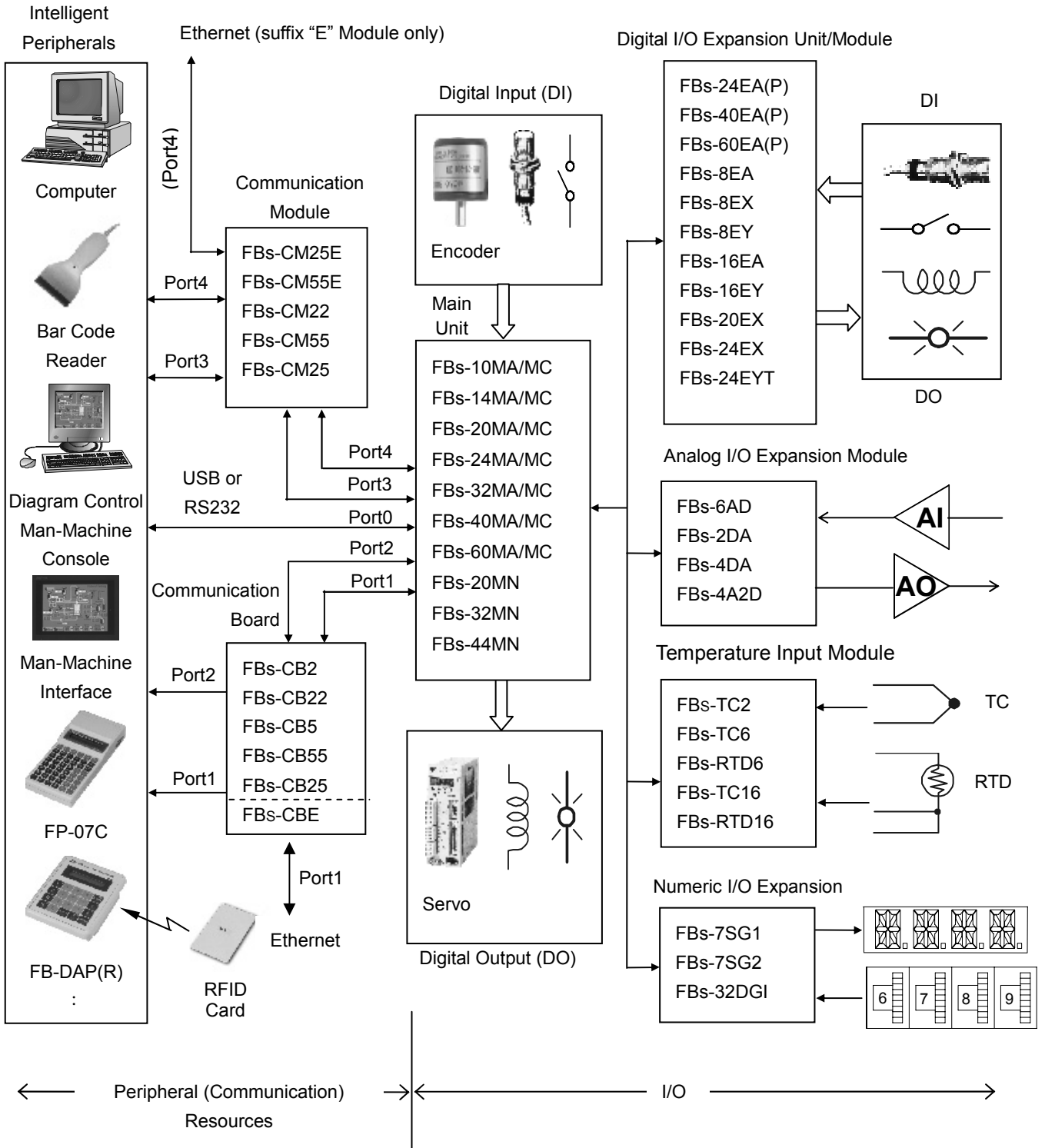

For the I/O of FBs-PLC, it can achieve a maximum of 256 point digital input (DI), 256 point digital output (DO), 64 word numeric input (NI), and 64 word numeric output (NO). Combined with various special interface modules, it can directly connect with devices such as Thermocouple, RTD, 7-segment LED display, and the Thumbwheel switch, which are shown on the right in the above figure.

Regarding communication resources, the FBs-PLC hardware can accommodate up to 5 communication ports (with a maximum speed of 921.6Kbps). In addition to providing the standard FATEK communication protocol, it also supports the Modbus master/slave protocol or any user-defined protocol. This functionality easily renders the connections with intelligent peripherals such as electronic scale, bar code reader, and various meters and gauges.

## 2.2 Formation of Multi-Unit System

By connections through communication ports and specific communication drivers, multiple Single-Unit PLC systems can be integrated to achieve resources sharing among multiple PLC or PLCs and its host computer. It is described as follows:

### 2.2.1 Connection of Multiple FBS-PLC (CPU Link)

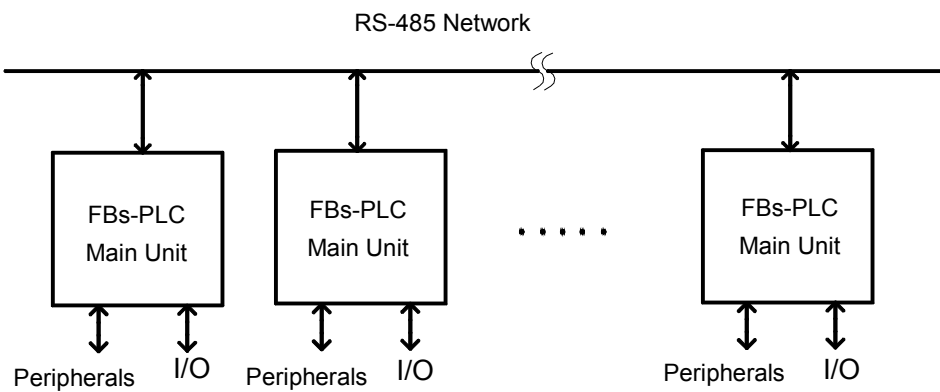

As shown in the figure, through the usage of high-speed RS-485 network, can easily establish the connections of 2~254 main units (each PLC with its own station number). All need to do is to write and execute CPU Link commands in one of the main units, which makes it the Master of the CPU Link network. No other command is necessary for other Slave units. The Master CPU will automatically collect the information or data in the specific areas of all units (including the Master) and put it into the Common Data areas(CDM) of all units. Thus all the units connected by network can share the data for each other and turning the finite Single-Unit system with limited I/O into a huge system.

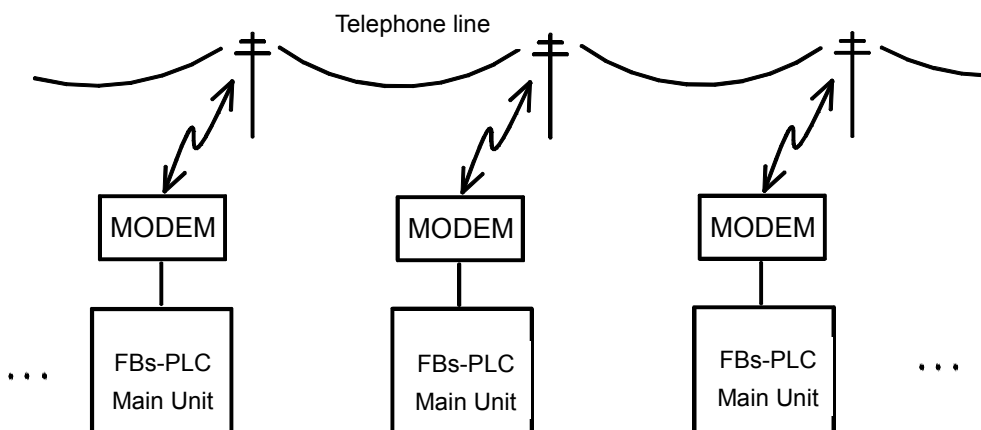

Besides the above area network connection, FBS-PLC can also be connected using MODEM via the phone line (either leased line or public phone line) to form remote multiple PLC Link. (When using a public phone line, the Master PLC will perform consecutive dialing for all its Slave PLC.)

### 2.2.2 Connection FBS-PLC with Host Computer or Intelligent Peripherals

Any one of the five communication ports on FBS-PLC can be used to connect to an upper-level computer or other systems, with this architecture, the FBS-PLC is playing the Slave role. FBS-PLC supports the FATEK and Modbus protocol. Connection can be established as long as the upper-level computer or intelligent peripherals use either one of the two protocols. In the application, in which driver for FATEK or Modbus is not available, FATEK also provide standard DDE communication server, which enables FBS-PLC to connect with any computer system supporting DDE. The following is the block diagram.

