

Chapter 5 Power Supply Wiring, Power Consumption Calculation, and Power Sequence Requirements

FBS-PLC internally has three kinds of circuit: a 5VDC logic circuit, a 24VDC output circuit, and a 24VDC input circuit. They are all powered by the built-in power supply of main/expansion units. Expansion modules other than main/expansion units do not contain any power supply and are powered by the power supply inside the main/expansion units or expansion power supply (FBS-EPOW). Main/expansion units or expansion power supply with their model numbers suffixed with “-D” means is operated by DC power source. Otherwise, AC power source is used.

 Note
In industrial environments, main power may irregularly experience a surge current or high voltage pulse caused by the start or shut down of high power equipment. Users are advised to take necessary measures (for example, the use of isolation transformer or other MOV suppression devices) for the protection of PLC and its peripherals.

5.1 Specifications of AC Power Sourced Power Supply and Wiring

The available AC power supplies of FBS-PLC are the 14 Watt (POW-16) supply for 10/14 PTs main unit, the 24 Watt (POW-24) supply for 20~60PTs main/expansion unit, and the 14 Watt expansion supply (FBS-EPOW) for expansion modules. Except that the FBS-EPOW is an independent module, POW-14 and POW-24 are to be installed on a main unit or inside an expansion unit, where their appearances are invisible. The following table lists the specifications:

Spec / Model		POW-14	POW-24	FBS-EPOW
Item	Voltage	100 ~ 240VAC -15% / +10%		
Input Range	Frequency	50 / 60HZ -5% / +5%		
Max. Power Consumption		21W	36W	21W
Inrush Current		20A@264VAC		
Allowable Power Interrupt		20ms(min.)		
Fuse Spec.		1A , 250VAC		
Isolation Type		Transformer/Photo Couple Isolation, 1500VAC/minute		
Output Power*1	5VDC(logic circuit)	N/A*2	5V , ±5% , 1A(max)	5V , ±5% , 0.4A(max)
	24VDC(output circuit)	24V±10% , 200mA(max)*3	24V , ±10% , 400mA(max)	24V , ±1% , 250mA(max)
	24VDC(input circuit)	24V , ±10% , 400mA(max)	24V , ±10% , 400mA(max)	24V , ±10% , 250mA(max)

Note *1 : The 5VDC (for logic circuit) output power and the 24VDC (for output circuit) power can be accessed from the “I/O expansion output header” located on the right side of the main/expansion units for expansion modules. And the 5VDC power is also used by communication board (CBxx) or communication module (CMxx). The 24VDC power for input circuits is provided from the farthest 2 upper left terminals (labeled “+24V OUT-”) on the input terminal block of main/expansion unit to input circuit in expansion module or other sensors.

Note *2 : The 5VDC power of 10/14PTs main unit is generated from the 24VDC power in the output circuit, with specifications of 5VDC±10% and 400mA (max) (Circuit is located on the I/O board of 10/14PTs main unit).

Note *3 : Without any I/O expansion interface, the 24VDC power in 10/14PTs main unit is for its output circuit alone and cannot be used for other purposes.



Note

The schematic diagram of AC power supply wiring in main/expansion units is shown below. Also be cautious about the following:

Please follow the wiring schemes regulated by local national standards to use single-pole switch (break hot wire "L"), or double-pole switch (break both "L" and "N"), to turn on or off the AC input power.

In wiring, hot wire "L" must be connected to the **L** terminal on unit, while the ground line "N" connected to the **N** terminal. Please use wires with diameters $1\text{mm}^2 \sim 2\text{mm}^2$.

All **G** terminals on main unit and expansion unit/module have to be connected to the EG (Earth Ground) terminal of main power system as shown in the figure below, with wire diameters larger than 2mm^2 .

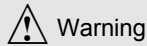

Warning

Output of power for sensor cannot be connected in parallel with other powers, in which the conflict between two sets of power will decrease their lifetime or cause immediate damage. This will induce unexpected malfunction of PLC and cause serious or even deadly damage to people or equipment.

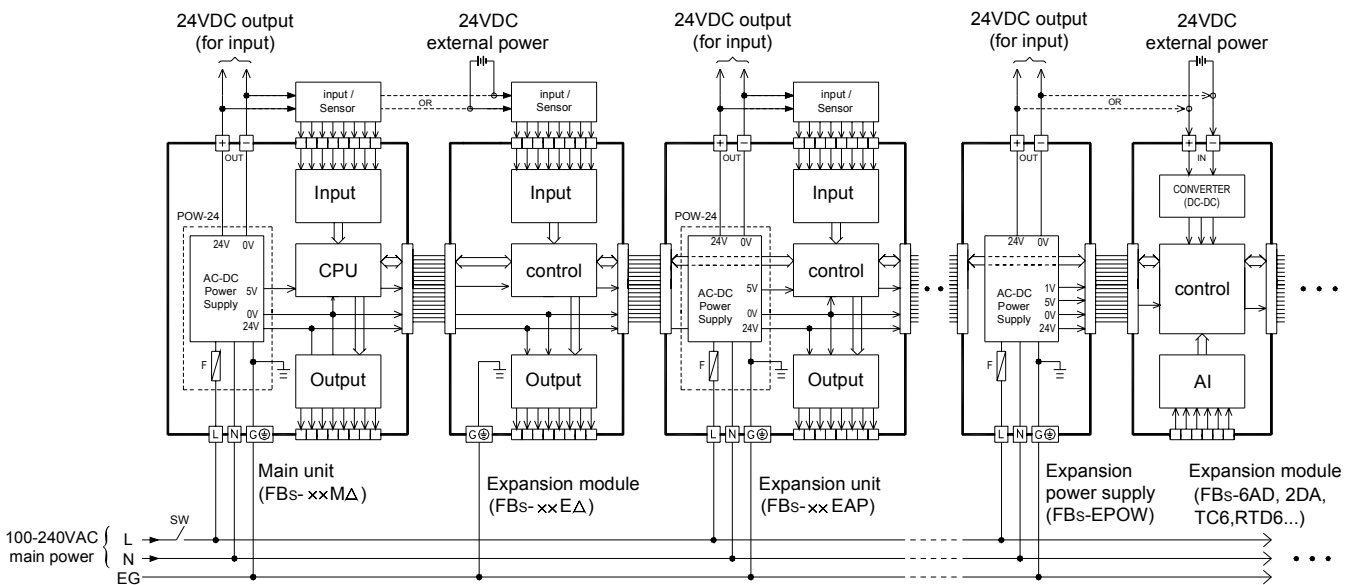

5.2 Specifications of DC Power Sourced Power Supply and Wiring

The available DC power sourced power supplies of FBs-PLC are the 10 Watt (POW-10-D) supply for 10/14PTs main unit, the 16 Watt (POW-16-D) supply for 20~60PTs main/expansion unit, and the 10 Watt expansion supply (FBs-EPOW-D) for expansion modules. The out power of DC source power supply is smaller than its AC counterpart because the power generated by the former only need to provide power to the 5VDC logic circuit and the 24VDC output circuit, while the power of 24VDC input circuit is derived directly by the 24VDC input power source through filter circuit. Besides the FBs-EPOW is an independent module, POW-14 and POW-24 are to be installed on a main unit or inside an expansion unit, where their appearances are invisible. The following table lists the specifications:

Spec. Item	Model	POW-10-D	POW-16-D	FBs-EPOW-D
	Rated Voltage	24VAC -15% / 20%		
Max. Power Consumption	15W	24W	15W	
Inrush Current	20A@24VDC			
Allowable Power Interrupt	20ms(min.)			
Fuse Spec.	3A · 250VAC			
Isolation Type	Transformer/Photo Coupler Isolation, 500VDC/minute			
Power*1 Output	5VDC(logic circuit)	N/A*2	5V, ±5%, 1A(max)	5V, ±5%, 0.4A(max)
	24VDC(output circuit)	24V±10%, 200mA(max)*3	24V, ±10%, 400mA(max)	24V, ±10%, 250mA(max)
	24VDC(input circuit)	Directly from input power, but limited by specifications of circuit and fuses, with capacity of 400mA(max.)		

Note *1 : The 5VDC (for logic circuit) output power and the 24VDC (for output circuit) power can be accessed from the "I/O expansion output header" located on the right side of main/expansion units for expansion modules. The 24VDC power for input circuit is provided from the farthest 2 upper left terminals (labeled "+24V OUT-") on the input terminal block of main/expansion unit to input circuit in expansion module or other sensors.

Note *2 : The 5VDC power of 10/14PTs main unit is generated by the oscillations of the 24VDC power in the output circuit, with specifications of 5VDC±10% and 400mA (max) (Circuit is located on the I/O board of 10/14PTs main unit)

Note *3 : Without any I/O expansion interface, the 24VDC power in 10/14PTs main unit is for its output circuit alone and cannot be used for other purposes.

⚠ Note

The schematic diagram of DC power supply in main/expansion unit is shown below. Also be cautious about the following:

Please follow the wiring schemes regulated by local national standards to choose single-pole switch (break 24V+) or double-pole switch (break both 24V+ and 24V-) in order to turn on or off DC input power.

Wiring of 24V+ input power must be connected to the terminal labeled by **+**, while the 24V- end is connected to the **-** terminal, Please use wires with diameters of 1mm²~2mm².

The **Ⓜ** terminals on main unit and all digital expansion units/modules must be connected to the EG (Earth Ground) terminal on main power system according to the scheme shown in the following figure, using wire diameters larger than 2mm².

⚠ Warning

Output of 24VDC power for input circuit cannot be connected in parallel with other powers, in which the conflict between two sets of power will decrease their lifetime or cause immediate damage. This will induce unexpected malfunction of PLC and cause serious or even deadly damage to people or equipment.

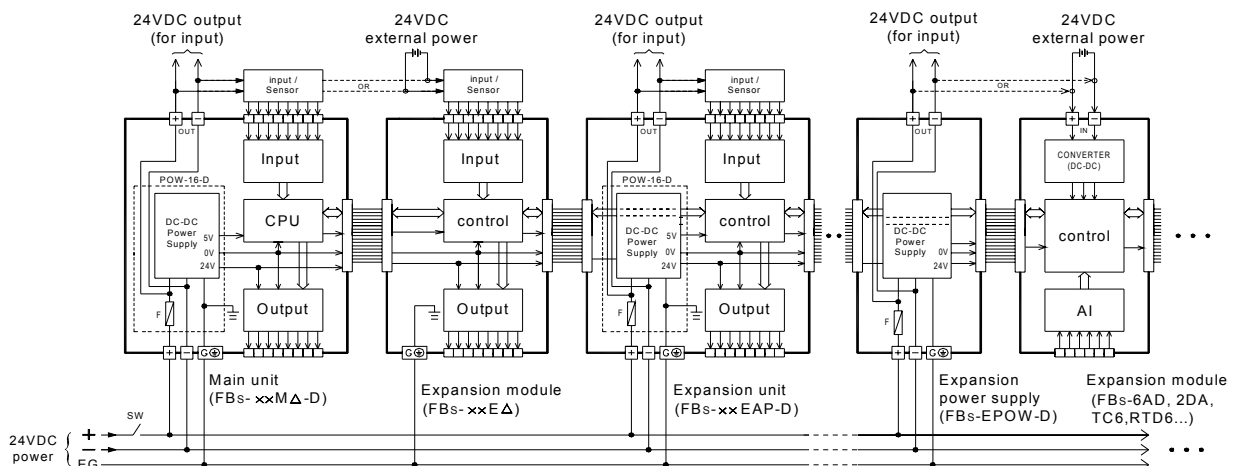

5.3 Residual Capacity of Main/Expansion Unit & Current Consumption of Expansion Module

Besides its own circuits usage, the residual capacities of three sets of built-in power supply of main/expansion unit are big enough for other expansion modules usage. In addition, the expansion power (FBs-EPOW) module can also provides the power for expansion modules usage. As each model of the main/expansion unit has different residual capacity, various models of expansion modules also consume different amounts of current. In practice, one has to consider the match between the two to avoid overload in any of the three sets of output power. In the following, the worst case of the available residual capacity in each main/expansion unit and the maximum power consumption of expansion modules are described below spare.

5.3.1 Residual Capacity of Main/Expansion Unit

Model		Extra Capacity	Output Power		
			5VDC(logic circuit)	24VDC(output circuit)	24VDC(input circuit)
Main Unit	FBs-10/14MA-⊙		300mA	—	340mA
	FBs-20MA-⊙		753 mA	335mA	310mA
	FBs-24MA-⊙		722 mA	325mA	295mA
	FBs-32MA-⊙		712 mA	315mA	262mA
	FBs-40MA-⊙		688 mA	295mA	244mA
	FBs-60MA-⊙		644 mA	255mA	190mA
	FBs-10/14MC-⊙		300 mA	—	340mA
	FBs-20MC-⊙		753 mA	335mA	310mA
	FBs-24MC-⊙		722 mA	325mA	295mA
	FBs-32MC-⊙		712 mA	315mA	262mA
	FBs-40MC-⊙		688 mA	295mA	244mA
	FBs-60MC-⊙		644 mA	255mA	190mA
	FBs-20MN-⊙		710mA	310mA	325 mA*
	FBs-32MN-⊙		670mA	297mA	280 mA*
	FBs-44MN-⊙		627 mA	276 mA	250 mA*
Expansion Unit	FBs-24EAP-⊙		948 mA	350mA	337mA
	FBs-40EAP-⊙		918 mA	320mA	292mA
	FBs-60EAP-⊙		880 mA	280mA	238mA

* except differential inputs (X0,1,4,5,8,9,12,13)

- Suffixed code—⊙ : hollow means AC power, —D DC power.
- In the above table, the residual capacity is calculated according to the most power-consuming model (for example, MCT) of in each main/expansion unit by its I/O point number, under the maximum load condition (with both DI and DO ON). The basic units for calculation are 7.5mA/PT for high/medium speed DI, 4.5mA/PT for low speed DI (Ultra high speed DI does not use the 24VDC power in input circuit), 10mA/PT for high speed DO, 7.5mA/PT for medium speed DO, and 5mA for low speed DO and relay output. (excluding the SSR model).
- See Sections 5.1 and 5.2 for the residual capacity of expansion power (-EPOW and -EPOW-D)

Warning

Either for the built-in power supply of the main/expansion unit or the expansion power supply for the expansion unit, the total amount of current cannot exceed the value listed in the above table. Any violation will cause a voltage drop by overloading the power supply, or intermittent powered with the supply in protection mode, either of which will result in unexpected action of PLC and cause harm to people or damage to equipment.

5.3.2 Maximum Current Consumption of Expansion Module

Without its own power supply, expansion modules must be supported by the main/expansion unit, expansion power, or external power supply (24VDC input circuit alone). The following table lists the maximum consumption current of each expansion module.

Model		Current	5VDC Logic Circuit	24VDC Output Circuit	24VDC Input Circuit
Digital I/O Expansion Module	FBS-24EA		52 mA	50mA	63mA
	FBS-40EA		82 mA	80mA	108mA
	FBS-60EA		120 mA	120mA	162mA
	FBS-8EA		30 mA	20mA	18mA
	FBS-8EX		30 mA	—	36mA
	FBS-8EY		27 mA	40mA	—
	FBS-16EA		40 mA	40mA	36mA
	FBS-16EY		39 mA	80mA	—
	FBS-20EX		46 mA	—	90mA
	FBS-24EX		48 mA	—	108mA
	FBS-24EYT		66 mA	—	—
Numeric I/O Expansion Module	FBS-32DGI		14 mA	—	36mA
	FBS-7SG1		14 mA	—	200 mA
	FBS-7SG2		14 mA	—	410 mA
	FBS-6AD		30 mA	—	45 mA
	FBS-2DA		18 mA	—	70 mA
	FBS-4DA		30 mA	—	130 mA
	FBS-4A2D		30 mA	—	80 mA
	FBS-TC2/TC6		32 mA	—	30 mA
	FBS-RTD6		32 mA	—	30 mA
	FBS-TC16		33 mA	—	30 mA
	FBS-RTD16		32 mA	—	30 mA
Communication Board (CB)	FBS-CB2		13 mA	—	—
	FBS-CB22		25 mA	—	—
	FBS-CB5		55 mA	—	—
	FBS-CB55		100 mA	—	—
	FBS-CB25		60 mA	—	—
Communication Module (CM)	FBS-CM22		18 mA	—	—
	FBS-CM55		100 mA	—	—
	FBS-CM25		67 mA	—	—
	FBS-CM25E		110 mA	—	—
	FBS-CM55E		120 mA	—	—
	FBS-CM25C		—	—	20 mA
	FBS-CM5R		—	—	20 mA
	FBS-CM5H		—	—	76 mA
Others	FBS-DAPB		—	—	—
	FBS-DAPC		—	—	—
	FP-07C		—	—	—

- The above table lists the required current for the maximum consumption in each expansion module. The 24VDC input circuit consumes 4.5mA less per point of OFF state DI in DI/O module, while the 24VDC output circuit consumes 5mA less per point of OFF state DO. The effect of power consumption variation regarding the ON/OFF state of DI/DO of expansion modules other than DI/O are less significant and can be neglected.
- The effect of residual capacity variation regarding the ON/OFF state of DI/DO for 5VDC logic circuit can be neglected.

5.4 Requirement of Power Sequence in Main Unit & Expansion Unit/Module

When the power is on, the FBS-PLC main unit first detects the type and number of expansion unit/module attached to its expansion interface and get the actual I/O configuration. Therefore, while the main unit performs detection, the power in expansion unit/module should be already UP, otherwise, the detected I/O configuration will not correct. Namely, the power of expansion unit/module should be ON simultaneously or even earlier. There will be no time sequence error when main unit/expansion unit/module are connected together to one power. If the expansion unit and main unit powered by different powers (or the same power but different switches), or external power supply is used for expansion modules, time sequence of both powers should be considered. To solve the problem of the expansion unit/module power not get ready before main unit power does, FBS-PLC provides a special R4150 register which can delay the detection time of I/O configuration. The time base of R4150 is 0.01sec with a default value of 100 (namely a 1sec delay), which can be set from 100~500 (1~5sec), as shown in the figure below. If the expansion unit power cannot be UP within 1sec after main unit power is ON, the R4150 time needs to be set longer to delay the detection by CPU. It cannot exceed 5sec, however, otherwise the configuration of expansion interface cannot be detected.

