

# Chapter 6 Digital Input (DI) Circuit

The FBS-PLC provides the ultra high speed differential double end 5VDC inputs (i.e., single input with two terminals without common) and the single-end 24VDC inputs which use the common terminal to save terminals. The response speeds of single-end common input circuits are available in high, medium and low. Because the double end input circuit has two independent terminals, it can be connected either in SINK or SOURCE (we will use the term SRCE) for input or in differential input wiring for line driver source. The single-end input circuit can be set to SINK or SRCE type by varying the wiring of the common terminals S/S inside PLC and external common wire of input circuits (see Sec. 6.3 for details).

## 6.1 Specifications of Digital Input (DI) Circuit

Item		5VDC Differential Input	24VDC Single-end Input				Note
		Ultra High Speed(HSC) 920KHz	High Speed(HSC) 100KHz	Medium Speed(HSC) 20KHz* <sup>1</sup>	Mid/Low Speed 470 μS* <sup>2</sup>	Low Speed (200Hz)	
Input Signal Voltage		5VDC±10%	24VDC±10%				
Input Current Threshold	ON Current	> 6 mA	>4mA		> 2.3mA		
	OFF Current	< 2 mA	< 1.5mA		< 0.9mA		
Maximum Input current		20mA	7mA		4.2 mA		
Input Status Indication		Displayed by LED: Lit when "ON", dark when "OFF"					
Isolation Type		Photo coupler signal isolation					
SINK/SRCE Wiring		Independent Wiring		Via variation of internal common terminal S/S and external common wiring			
List of Input Response Speed for Various Models	FBs-20MN	X0,1		X2~11			* <sup>1</sup> : Limit of input speed in MA model is 10KHz
	FBs-32MN	X0,1,4,5		X2,X3,X6~15	X16~19		
	FBs-44MN	X0,1,4,5,8,9,12,13		X2,3,6,7,10,11,14,15	X16~27		
	FBs-10MC		X0,1	X2~5			
	FBs-14MC		X0,1	X2~7			
	FBs-20MC		X0,1	X2~11			
	FBs-24MC		X0,1	X2~13			
	FBs-32MC		X0,1	X2~15	X16~19		
	FBs-40MC		X0,1	X2~15	X16~23		
	FBs-60MC		X0,1	X2~15	X16~35		
	FBs-10MA			X0~3	X4~5		
	FBs-14MA			X0~3	X4~7		
	FBs-20MA			X0~3	X4~11		
	FBs-24MA			X0~3	X4~13		
	FBs-32MA			X0~3	X4~19		
	FBs-40MA			X0~3	X4~23		
	FBs-60MA			X0~3	X4~35		
Expansion Unit/Module					All Input Points		
Noise Filtering Time Constant* <sup>3</sup>		DHF(0ns ~ 15ms) + AHF(470ns)		DHF(0 ~ 15ms) + AHF(470 μs)		AHF(4.7ms)	DHF : Digital Hardware Filter AHF : Analog Hardware Filter

\* : The standard product of MC-type High-Speed input is 2 points, it can extend to 3~8points (Option). Every increment one High-speed input point, and decrement one Middle-speed input point relatively. Only X4~X5,X8~X9 and X12~X13 input can be extended, and the priority is low serial-number to High serial-number.

## 6.2 Structure and Wiring of 5VDC Ultra High Speed Differential Input Circuit

Only the MN main unit of FBs provides the 5VDC ultra high speed differential input circuit, which is mainly used for the input of hardware high speed counter (HHSC) with a maximum working frequency up to 920 KHz. In practice, to ensure the high speed and high noise immunity, please use Line-Driver for differential line driving. In environments with small noise and medium working frequency ( $< 100\text{KHz}$ ), however, it can be changed to the 5VDC single-end SINK or SRCE input or to the 24VDC single-end SINK or SRCE input by connecting a  $3\text{K}\Omega/0.5\text{W}$  resistor in series, as shown in the figure below.

- (A) Wiring of 5VDC differential input for Line-Driver driving (with frequency up to 920KHz for high speed and environments with large noise)

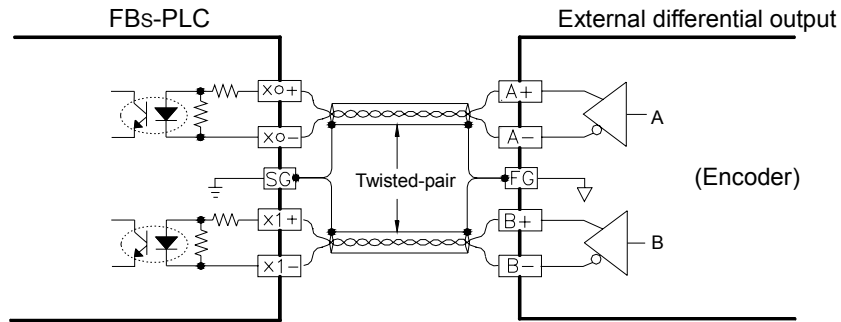

- (B) Wiring of 5VDC differential input to 5VDC single SINK or SRCE input (100KHz)

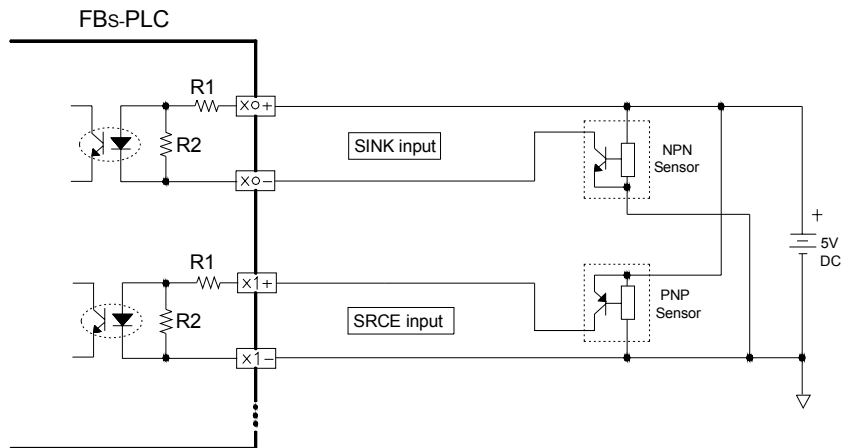

- (C) Method of converting 5VDC differential input to 24VDC single-end SRCE input (frequency  $< 100\text{KHz}$ )

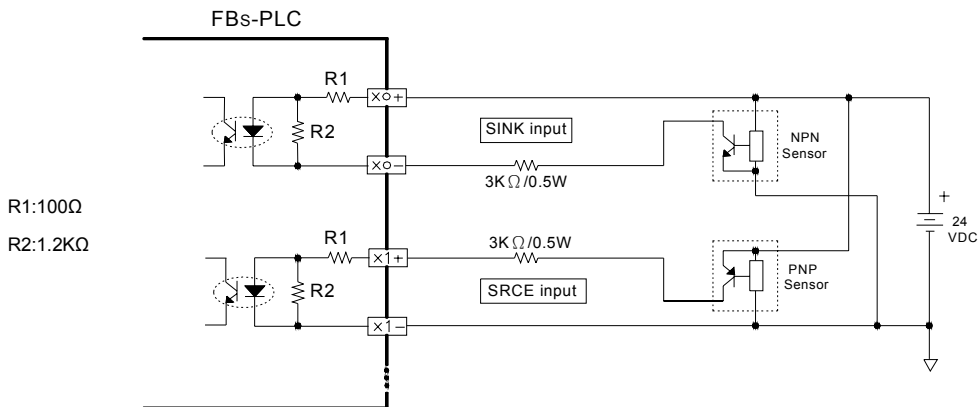

## 6.3 24VDC Single-End Input Circuit and Wiring for SINK/SRCE input

The 24VDC single-end digital input circuits of FBS-PLC are available for high, medium and low speed. They all have the similar circuit structures but with different response speeds. To save input terminals, the circuit of single-end input is implemented by connecting one end of all input points (photo coupler) inside the PLC to the same internal common point labeled as S/S. The other end of each input circuit is connected to corresponding terminals such as X0, X1, X2, etc. The S/S common terminal and N single-end inputs comprise of N digital inputs (i.e., only N+1 terminals are used for N terminals). Therefore, we call this type of input structure the single-end input. The user also needs to do the same thing when making the connection of external digital input devices. Namely, the one end of all input devices (e.g., buttons, switches) are connected together and called the external common wire, while the other ends of input circuits are connected to the input terminals X0, X1, X2, etc., of PLC. Then finish it by connecting the external common wiring and internal common terminal S/S to the positive/negative terminals of the 24VDC power. When connect the internal common terminal S/S to 24V+(positive) and the external common wire to 24V- (negative), then the circuit serve as SINK input. On the contrary, while exchange the wiring of the above internal and external common will serve as a SRCE input. The above wiring schemes can illustrated below:

- Wiring of single-end common SINK input (internal common terminal S/S → 24V+, external common wiring → 24V-)

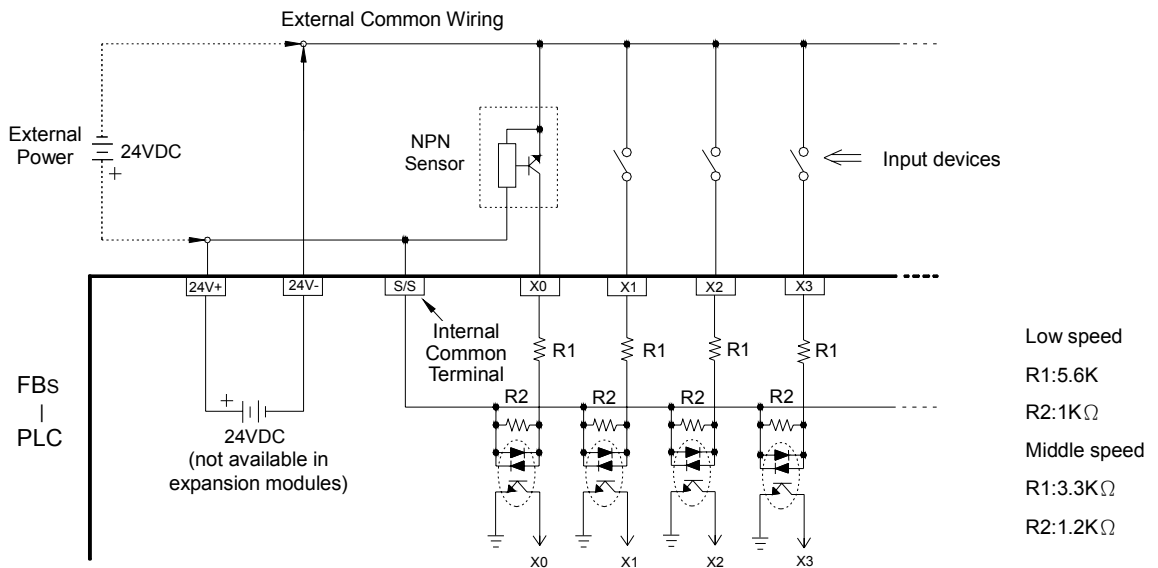

- Wiring of single-end common SRCE input (internal common terminal S/S → 24V-, external common wiring → 24V+)

